

Eco-Block Pty Ltd

Wall System

Technical Manual

Contents

Preface

1. Eco-Block Wall System Applications

2. Building Code of Australia Compliance

3. Structural Design

4. Fire Performance

5. Acoustic Performance

6. Thermal Performance

7. Detailing

8. Specifications

9. Sustainability

Appendix A - Eco-Block Wall System Applications

Appendix B - Building Code of Australia Compliance

Appendix C - Structural Design

Appendix D - Fire Performance

Appendix E - Acoustic Performance

Appendix F - Thermal Performance

Appendix G - Detailing

Appendix H - Specifications

Appendix I - Sustainability

Preface

Eco-Block Wall System

Eco-Block Wall System is an innovative wall system, consisting of a reinforced concrete core, bounded by polystyrene panels that act as both insulation and permanent formwork.

Technical Manual to be used by Professional Architects, Engineers and Builders

This manual is intended for use by qualified and experienced architects, engineers and builders. The authors, publishers and distributors of this manual, sample specification and the associated drawings do not accept any responsibility for incorrect, inappropriate or incomplete use of this information.

Using this Manual

This manual, including the design recommendations, sample specification and the associated drawings, are available in electronic format, with the express intention that designers will edit them to suit the particular requirements of specific construction projects.

Basis of the Specification and Drawings

This manual has been prepared in the context of the Building Code of Australia. Architects, engineers and builders should make themselves aware of any recent changes to these documents, to any Standards referred to therein or to local variations or requirements. The authors, publishers and distributors of this specification and the associated drawings do not accept any responsibility for failure to do so.

In the preparation of this manual, the following convention has been adopted.

- All building design and construction must comply with the Building Code of Australia and any relevant Australian Standards referred to therein.
- If the construction is not covered by either Building Code of Australia or Australian Standards, construction should comply with a balanced combination of current practice, engineering principles and supplier's information.

1. Eco-Block Wall System Applications

Eco-Block Wall System is an innovative wall system, consisting of a reinforced concrete core, bounded by polystyrene panels that act as both insulation and permanent formwork. It finds application in:

- Housing
- Industrial and Commercial Buildings

Important Note:

The use in Industrial and Commercial buildings is contingent on satisfying BCA Vol 1 CP3 and CP4 (performance clauses on the spread of fire and smoke), and Part C.1.10, the DTS requirement for C1.10 and Specification C1.10. This may be achieved by various means, including (but not limited to) the inclusion of fire-resistant plasterboard sheathing, sprinkler systems etc. It is essential that the BCA be examined closely in these instances.

Design Procedure

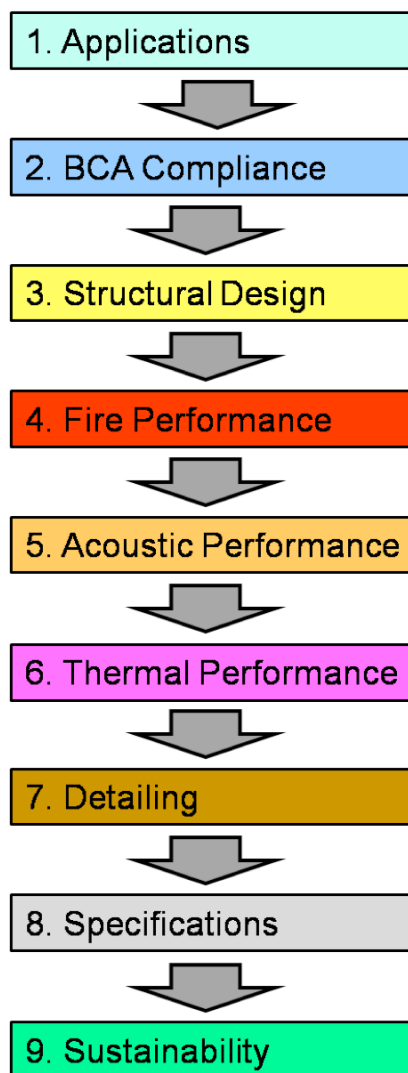

1. Determine the building use and the Building Class, as defined in the Building Code of Australia.
2. Determine the appropriate clauses of the Building Code of Australia, to which the Eco-Block Wall System must comply.
3. Carry out structural design of the Eco-Block Wall System and its supporting structure.
 - Determine the wind loads, using AS/NZS 1170.2 (or AS 4055 for detached dwellings). Determine the earthquake loads, using AS 1170.4. Determine all other structural loads and loading combinations, using AS/NZS 1170.0, 1 and 3.
 - Check the bending, shear, compression, and connection strength for out-of-plane loads such as wind or earthquake.
 - Check the shear resistance and connection strength for in-of-plane horizontal loads such as wind or earthquake.
 - Check the compressive capacity and resistance to concentrated loads for gravity and other vertical loads. Where appropriate, check connection strength.
4. Determine the fire resistance requirements of structural adequacy, integrity and insulation (if any), using the BCA, and whether the Eco-Block Wall System has sufficient fire resistance. For structural adequacy, the support locations, strength and stiffness must be considered.
5. Determine acoustic requirements, using the BCA, and whether the Eco-Block Wall System has sufficient sound attenuation.
6. Determine the thermal insulation requirements, using the BCA, and whether the Eco-Block Wall System has sufficient thermal resistance.
7. Design and detail associated items, such as lintels, roof anchorages, flashings and the like.
8. Prepare a comprehensive specification.
9. Check any sustainability criteria and confirm compliance.

Detached, Duplex and Some Grouped Residential Eco-Block Wall Systems

The Detached, Duplex and Some Grouped Residential Eco-Block Wall Systems described in this manual are generally BCA Class 1(a) buildings that comply with the geometry limitations of AS 3700 Figure 12.1. They are an Australian adaptation of the Flat ICF Wall System, described in the following publication:

Prescriptive Design of Exterior Concrete Walls for One- and Two-Family Dwellings, Portland Cement Association National Standards Development Committee, PCA 100-2007

Three systems are covered by this manual:

- Eco-Block 230
- Eco-Block 280
- Eco-Block 330

The systems consist of:

- N20 (20MPa) concrete core, either 101, 152 or 203 mm thick
 - Eco-Block 230 Series – Concrete core is 101 mm thick
 - Eco-Block 280 Series – Concrete core is 152 mm thick
 - Eco-Block 330 Series – Concrete core is 203 mm thick
- Two “flat” Class H expanded polystyrene ICF side panels, in accordance with AS 1366.3-1992, each measuring 1219 mm long x 406 mm high x 64 mm thick. Each pair of side panels is connected by a minimum of 12 Eco-Block propriety connectors at 203 mm centres horizontally.
 - Eco-Block 230 Series – Connector length is 101 mm
 - Eco-Block 280 Series – Connector length is 152 mm
 - Eco-Block 330 Series – Connector length is 203 mm
- Steel or equivalent fibres incorporated into the concrete, dosed at 24 kg/m³
- N12 L (700 x 260 cog) vertical starter bars, set in the concrete slab at centres set out in Table 3.1 to provide lap of 500 mm. As an alternative, it shall be permissible to set straight starter bars into the concrete slab with two part epoxy or equivalent.
- N12 vertical steel reinforcement at centres set out in Table 3.1, lapped 500 mm with the starter bars and cogged at the top of the wall to lap with the horizontal reinforcement
- At least one additional N12 vertical steel reinforcing bar adjacent to each opening
- 2-N12 bars or 1-N16 at the top of the wall, continuous around the building.
- Lintels as set out in Table 3.2, above each window and door opening and the 2-N12 bars continuous around the building.
- 1-N12 horizontal bar below each window opening

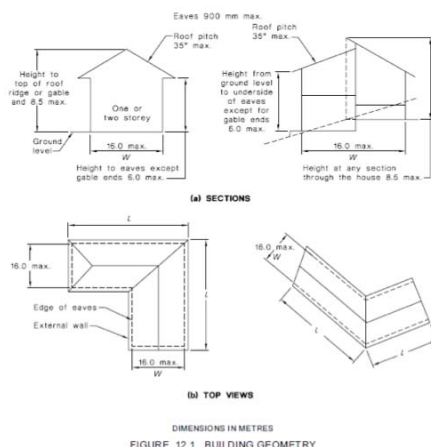

Refer to AS 3700 Figure 12.1

Commercial / Industrial Eco-Block Wall System

The Commercial / Industrial Eco-Block Wall Systems described in this manual are generally BCA Class 1(b), and Class 2 to 9 buildings that outside the geometry limitations of AS 3700 Figure 12.1. They are an Australian adaptation to the requirements of AS 3600 *Concrete structures*, of the Flat ICF Wall System, described in the following publication:

Prescriptive Design of Exterior Concrete Walls for One- and Two-Family Dwellings, Portland Cement Association National Standards Development Committee, PCA 100-2007

Three systems are covered by this manual:

- Eco-Block 230 CI
- Eco-Block 280 CI
- Eco-Block 330 CI

Note:

In addition to these standard sizes, the core concrete thickness of Eco-Block walls may be used up to 600 mm.

The systems consist of:

- N20 (20 MPa) concrete core, either 101, 152 or 203 mm thick
 - Eco-Block 230 CI Series – Concrete core is 101 mm thick
 - Eco-Block 280 CI Series – Concrete core is 152 mm thick
 - Eco-Block 330 CI Series – Concrete core is 203 mm thick
- Two “flat” Class H expanded polystyrene ICF side panels, in accordance with AS 1366.3-1992, each measuring 1219 mm long x 406 mm high x 64 mm thick. Each pair of side panels is connected by a minimum of 12 Eco-Block propriety connectors at 203 mm centres horizontally.

Eco-Block 230 CI Series – Connector length is 101 mm

Eco-Block 280 CI Series – Connector length is 152 mm

Eco-Block 330 CI Series – Connector length is 203 mm

- Reinforcement complying with AS 3600 for particular applications, including:
 - vertical loading;
 - out-of-plane horizontal loading; and/or
 - in-plane horizontal loading
 in accordance with the Building Code of Australia; and AS/NZS 1170.0, 1, 2 and 3 as applicable, and AS 1170.4.
- Details shall be generally as show in the following manual, but modified to suit the BCA and Australian Standards noted above.

Prescriptive Design of Exterior Concrete Walls for One- and Two-Family Dwellings, Portland Cement Association National Standards Development Committee, PCA 100-2007.

2. Building Code of Australia Compliance

Scope

This section describes the means whereby Eco-Block Wall System satisfies the performance requirements of the Building Code of Australia.

Performance Requirements, Deemed-to-Satisfy & Alternative Solutions

All building design must comply with the relevant state regulations, which are incorporated into the Building Code of Australia Volume 1 and Volume 2. These define the performance requirements, generally in very broad terms, and the means of compliance through the following paths, each of which has equal status under the Building Code of Australia.

- Deemed-to-Satisfy Provisions, which may include:
 - Acceptable Construction Manuals (e.g. nominated Standards)
 - Acceptable Construction Practice (e.g. forms of construction reproduced in the Building Code of Australia itself)
- Alternative Solutions (e.g. Designs based on test results and engineering principles).

Definitions

These definitions are taken from the Building Code of Australia Volume 2. Some of the definitions of in Volume 1 have slightly different wording, but essentially mean the same.

Objective ... means a statement contained in the Building Code of Australia which is considered to reflect community expectations.

Functional Statement ... means a statement which describes how buildings and building elements achieve the Objectives.

Performance Requirement ... means a requirement which states a level of performance which a Building Solution must meet.

Deemed-to-Satisfy Provisions ... means the provisions contained in Section 3 which are deemed to comply with the Performance Requirements.

Alternative Solution ... means a Building Solution which complies with the Performance Requirements other than by reason of complying with the Deemed-to-Satisfy Provisions.

Eco-Block Wall System in the Context of the Building Code of Australia

The use of Eco-Block Wall System in buildings must comply with the Building Code of Australia. Because Eco-Block Wall System is outside the scope of the most relevant referenced documents, AS 3700 and AS 3600, its use must be treated as an Alternative Solution.

Building Regulation Clauses Establishing the Basis of an Alternative Solution

Appendix B sets out the relevant clauses of the Building Code of Australia that provide the basis of establishing an Alternative Solution for the use of Eco-Block Wall System in buildings.

Detached, Duplex and Some Grouped Residential Eco-Block Wall System

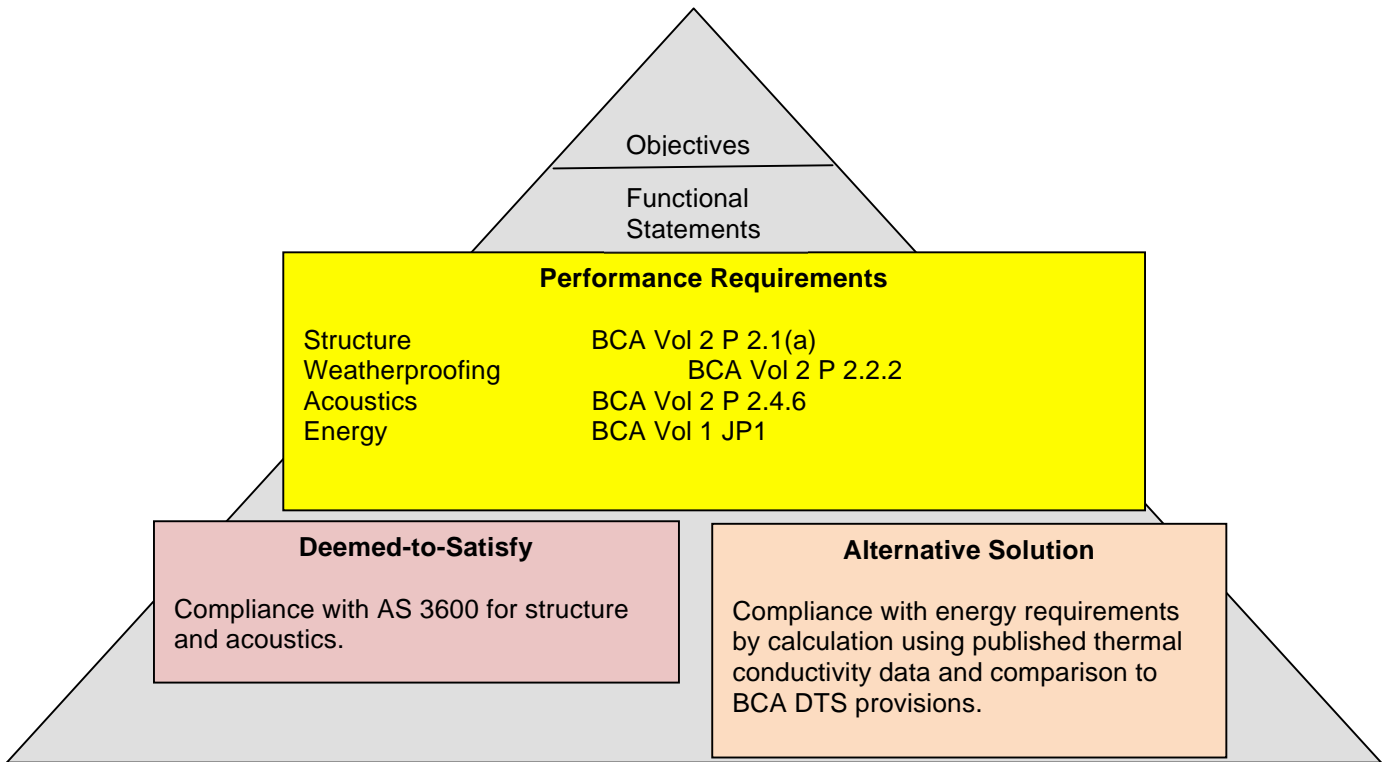

Commercial / Industrial Eco-Block Wall System

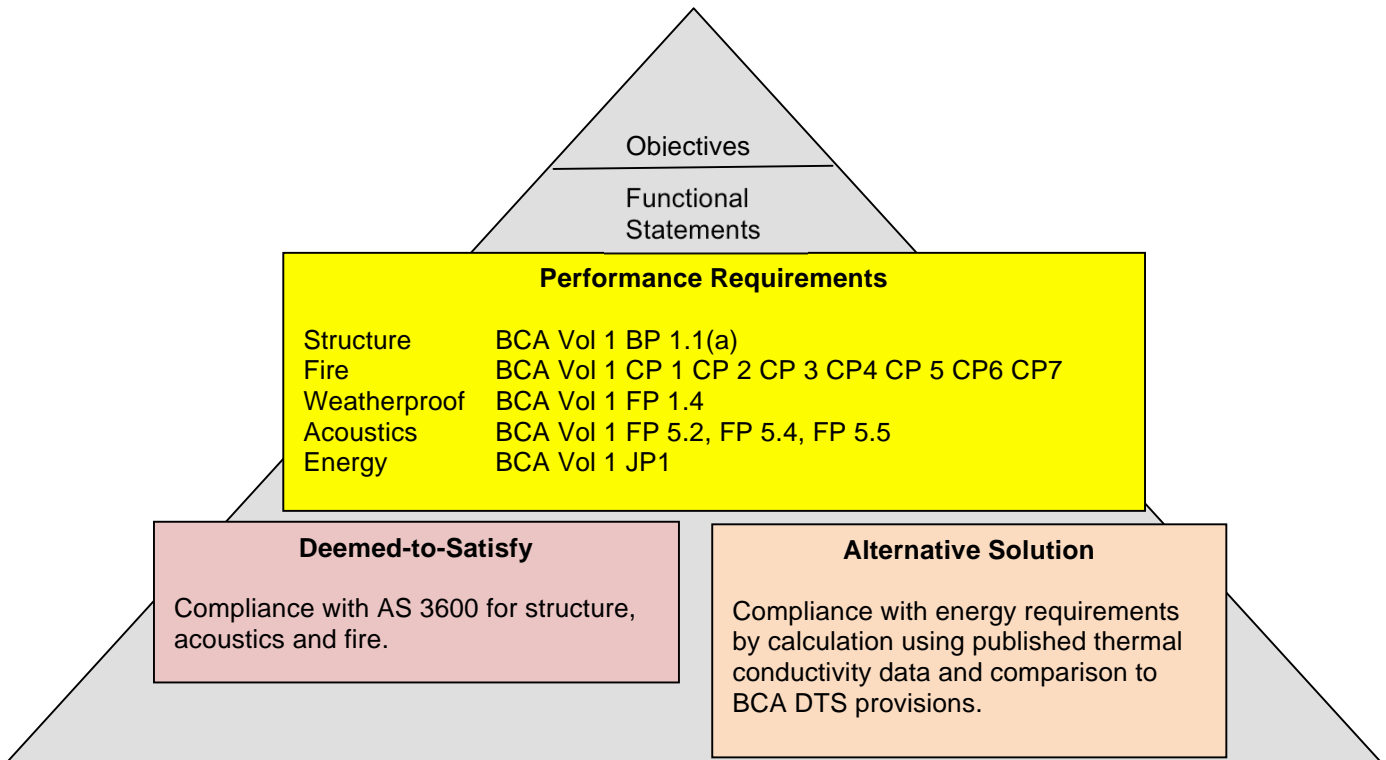

Compliance Statement - Detached, Duplex and Some Grouped Residential Eco-Block Wall Systems

This is to certify that Detached, Duplex and Some Grouped Residential Eco-Block Wall Systems (Eco-Block 230, Eco-Block 280 and Eco-Block 330) comply with Building Code of Australia (BCA) as follows:

1. Volume 2 P2.1(a) - When constructed in accordance "Eco-Block Australia Wall System Technical Manual", September 2008, the product will provide a building superstructure that complies with this part in respect of structural adequacy.
2. Volume 2 P2.2.2 - When constructed in accordance "Eco-Block Australia Wall System Technical Manual", September 2008, the product will provide a building envelope that complies with this part in respect of weatherproofing,
3. Volume 2 P 2.4.6 - When constructed in accordance "Eco-Block Australia Wall System Technical Manual", September 2008, the product will provide a building envelope that complies with this part in respect of acoustics,
4. Volume 2 P2.6.1 - When constructed in accordance "Eco-Block Australia Wall System Technical Manual", September 2008, the product will provide a wall system that complies with this part in respect of thermal resistance not less than $R 3.5 \text{ m}^2\text{K/W}$.
5. State Additions: Nil

Subject to the following conditions and limitations:

1. Product selection, and incorporation into the building design, shall be made by a professional Engineer who:
 - Has qualifications and experience acceptable to the relevant approval authorities;
 - Has received training in the use, application and technical aspects of the product; and
 - Has ready access to all the relevant technical information and test reports related to the product use.
2. Product installation shall be carried out by a competent tradesman under the direction of a Builder, both of whom:
 - Have qualifications and experience acceptable to the relevant approval authorities;
 - Have received training and accreditation (by Eco-Block) in the use, application and technical aspects of the product; and
 - Have ready access to all the relevant technical information and test reports related to the product use.

Notes:

The state administrations have differing requirements in respect of qualifications of structural engineers, including registration on the National Professional Engineers Register, and Registered Professional Engineer Queensland.

Compliance Statement - Commercial / Industrial Eco-Block Wall Systems

This is to certify that Commercial / Industrial Eco-Block Wall Systems (Eco-Block 230 CI, Eco-Block 280 CI and Eco-Block 330 CI) comply with Building Code of Australia (BCA) as follows:

1. Volume 1 BP 1.1(a) - When constructed in accordance “Eco-Block Australia Wall System Technical Manual”, September 2008, the product will provide a building superstructure that complies with this part in respect of structural adequacy.
2. Volume 1 - FP1.4 - When constructed in accordance “Eco-Block Australia Wall System Technical Manual”, September 2008, the product will provide a building envelope that complies with this part in respect of weatherproofing,
3. Volume 1 - FP 5.2, FP 5.5 - When constructed in accordance “Eco-Block Australia Wall System Technical Manual”, September 2008, the product will provide a building envelope that complies with this part in respect of acoustics,
4. Volume 1 J1.2(a) - When constructed in accordance “Eco-Block Australia Wall System Technical Manual”, September 2008, the product will provide a wall system that complies with this part in respect of thermal resistance not less than R 3.5 m²K/W.
5. Volume 1 CP1, CP2, CP3, CP4, CP5, CP6, CP7 - When constructed in accordance “Eco-Block Australia Wall System Technical Manual”, September 2008, the product (with 10 mm plasterboard internal lining and fibre-cement external lining) will provide a wall system that complies with this part in respect of fire resistance as per the following table; for.

System	Thickness of concrete core Mm	Fire Resistance Levels Structural / Integrity / Insulation mins / mins /mins
Eco-Block 230 CI	101	90/90/90
Eco-Block 280 CI	152	180/180/180
Eco-Block 330 CI	203	240/240/240
Walls must be supported top and bottom, and be designed in accordance with AS 3600.		

6. State Additions: Nil

Subject to the following conditions and limitations:

1. Product selection, and incorporation into the building design, shall be made by a professional Engineer who:

- Has qualifications and experience acceptable to the relevant approval authorities;
- Has received training in the use, application and technical aspects of the product; and
- Has ready access to all the relevant technical information and test reports related to the product use.

2. Product installation shall be carried out by a competent tradesman under the direction of a Builder, both of whom:

- Have qualifications and experience acceptable to the relevant approval authorities;
- Have received training and accreditation (by Eco-Block) in the use, application and technical aspects of the product; and
- Have ready access to all the relevant technical information and test reports related to the product use.

Notes:

The state administrations have differing requirements in respect of qualifications of structural engineers, including registration on the National Professional Engineers Register, and Registered Professional Engineer Queensland.

3. Structural Design

Scope

This section covers the structural design of Eco-Block Wall System for compliance with the structural requirements of the Building Code of Australia.

Forms of Construction

Eco-Block Wall System is an innovative reinforced concrete wall system, incorporating permanent polystyrene forms. It may be used in reinforced applications when constructed as large panels subjected to relatively high wind or earthquake loads. There are two options:

- *Detached, Duplex and Some Grouped Residential Eco-Block Wall Systems (Eco-Block 230, Eco-Block 280 and Eco-Block 330)*
- Commercial / Industrial Eco-Block Wall Systems (Eco-Block 230 CI, Eco-Block 280 CI and Eco-Block 330 CI)

Building Code of Australia

The structural design of Eco-Block Wall System within buildings is regulated by the Building Code of Australia. Refer to the section "Compliance with the Building Code of Australia".

Relevant Standard

Detached, Duplex and Some Grouped Residential Eco-Block Wall Systems

Detached, Duplex and Some Grouped Residential Eco-Block Wall Systems (Eco-Block 230, Eco-Block 280 and Eco-Block 330) incorporate steel reinforcement at spacings that do not comply with AS 3600 *Concrete structures*. Therefore these systems must be treated, under the BCA¹, as an Alternative Solution. The most relevant BCA referenced document is AS 3700 *Masonry structures*, which will be used as the comparison document.

Commercial / Industrial Eco-Block Wall Systems

Commercial / Industrial Eco-Block Wall Systems (Eco-Block 230 CI, Eco-Block 280 CI and Eco-Block 330 CI) incorporate steel reinforcement at spacings that do comply with AS 3600 *Concrete structures*. Therefore these systems may be treated as a Deemed-to-Satisfy solution under the BCA.

Loads

Eco-Block Wall System walls should be designed to withstand the loads set out in the Building Code of Australia and Standards:

- AS/NZS 1170.0 Structural design actions Part 0: General principles
- AS/NZS 1170.1 Structural design actions Part 1: Permanent, imposed and other actions
- AS/NZS 1170.2 Structural design actions Part 2: Wind actions
- AS/NZS 1170.3 Structural design actions Part 3: Snow and ice actions
- AS 1170.4 Structural design actions Part 4: Earthquake actions in Australia
- AS 4055 Wind loads for housing

Capacity Tables

The following pages set out capacity tables for Eco-Block Wall System subject to horizontal pressures as would arise from wind or earthquake loading and vertical gravity loading. The basis of these tables is set out in Appendix C. The fixing of Eco-Block Wall System into the supporting structure should be carried out in accordance with Appendix C.

Design for Other Actions

The design of Eco-Block Wall System for other actions, such as Compression and Shear, should be carried out in accordance with the method set out in Appendix C.

¹ Building Code of Australia

Option 1

Detached, Duplex and Some Grouped Residential Eco-Block Wall Systems Eco-Block 230, Eco-Block 280 and Eco-Block 330

Scope

The following tables are applicable only to single-storey and two-storey Detached, Duplex and Some Grouped Residential Eco-Block Wall Systems designed similar to AS 3700 *Masonry structures*. Particular reference is made to AS 3700 Section 12.

Exclusions

Because the form of construction described in Option 1 has been justified from engineering principles and by comparison to AS 3700 (including Section 12), the scope of the option has been limited to single-storey and two-storey Detached, Duplex and Some Grouped Residential Construction. For construction beyond this scope (i.e. multi-storey construction, multi-unit villas, multi-unit townhouses or commercial/industrial buildings), should be designed in accordance with AS 3600 *Concrete structures*.

Justification

The following justification provides the basis for the tables and designs contained in Option 1 of this manual.

1. The Eco-Block 230, Eco-Block 280 and Eco-Block 330 external wall systems consist essentially of a continuous partially reinforced concrete core 101, 152 or 203 mm thick (respectively), with wide-spaced vertical reinforcement tied integrally via starter bars to a reinforced concrete footing or slab system complying with AS 2870, and a continuous horizontal bond beam or lintel are around the top of the external walls. Reinforced lintels and sill are also included. Permanent polystyrene forms contribute as described below.
2. Because the Eco-Block systems are very similar in behaviour and design to partially reinforced concrete blockwork described in AS 3700 Section 12, their use may be justified in applications for which such partially reinforced concrete blockwork is in common use; viz. single-storey and two-storey Detached, Duplex and Some Grouped Residential applications.
3. Although the scope of the Eco-Block 230, Eco-Block 280 and Eco-Block 330 wall systems (Option 1) has been limited in this manual to single-storey and two-storey Detached, Duplex and Some Grouped Residential applications, this should not be interpreted as suggesting that their use in other applications is inappropriate. If a designer wishes to use these systems in other applications, which are beyond the scope described herein, it would be appropriate for the designer to prepare an Alternative Solution (as described in the Building Code of Australia) for the particular application.
4. By incorporating steel starter bars to the footing/slab system, and wide-spaced vertical reinforcement, a continuous reinforced bond beam, reinforced lintels and reinforced sills within a continuous concrete core; an Eco-Block building will behave as a "stiff box" spanning over "doming" or "dishing" foundations.

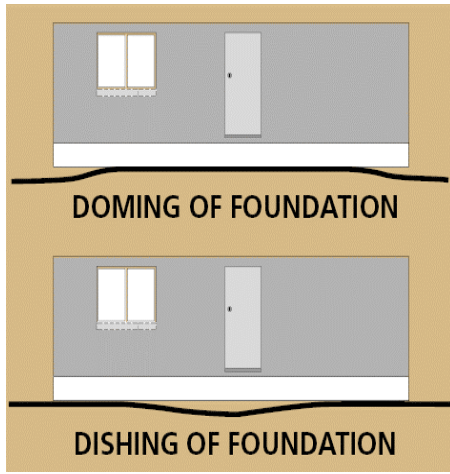

5. This “stiff box” behaviour is described in the Concrete Masonry Association of Australia Manual MA55, Design and Construction of Concrete Masonry Buildings, for Partially Reinforced Concrete Masonry buildings. These are common throughout northern Australia. Walls consisting of strong panels of reinforced hollow concrete blockwork are tied monolithically to the concrete footings or slabs. The strong stiff combination of wall and slab/footing span discrete distances over expanding or shrinking foundations, without cracking or showing distress. Integrated footing/wall deep-beam systems in which the reinforced concrete slab or footing and the concrete masonry wall are structurally connected may be considered to act compositely to resist the loads when soil movement occurs.
6. Eco-Block 230, Eco-Block 280 and Eco-Block 330 external wall systems (Option 1) have been designed using the principles set out in AS 3700 for the design of the vertical reinforcement, steel starter bars, reinforced bond beams, reinforce lintels and reinforced sills of Partially Reinforced Concrete Masonry Systems.
7. One difference between Eco-Block 230, Eco-Block 280 and Eco-Block 330 external wall systems (Option 1) and Partially Reinforced Concrete Masonry Systems is the fact that the masonry system incorporates masonry units set in mortar, while the Eco-Block systems feature continuous concrete.
 - Both systems are subject to shrinkage, but the incorporation of the steel reinforcement restrains movement and minimizes shrinkage cracking.
 - The Eco-Block wall system includes steel or equivalent fibres incorporated into the concrete, dosed at 24 kg/m^3 . The incorporation of steel or equivalent fibres in the concrete limits the formation of shrinkage cracks, thus eliminating potential problems due to corrosion, water penetration and the like.
 - The Eco-Block wall system includes two 64 mm “flat” Class H expanded polystyrene ICF side panels, in accordance with AS 1366.3. The external surface of the panel is coated with a high-build acrylic render, or texture coat or other cladding. The internal surface of the panel is also painted, usually over 10 mm gypsum plasterboard lining; or coated with a high-build acrylic render, or texture coat or other cladding. The use of these coating and lining systems ensures the water-resistant properties of the outer layers of the system, also eliminating potential problems due to corrosion, water penetration and the like, and promotes efficient curing of the concrete.
 - The inclusion of the coating and lining systems described above, enhances the curing of the core concrete, ensuring that any shrinkage is less than the values expected in other exposed concrete wall systems.

Design Methodology

For details of the design methodology used in this manual for the Eco-Block 230, Eco-Block 280 and Eco-Block 330 external wall systems (Option 1), refer to Appendix 3.

Technical Opinion

The cumulative effect of the points above is to give confidence that the Eco-Block 230, Eco-Block 280 and Eco-Block 330 external wall systems (Option 1) are suitable for the walls of single-storey and two-storey detached, duplex and some grouped residential buildings, when designed and constructed in accordance with this Manual.

**Table 3.1 – Vertically Reinforced Walls
Maximum Reinforcement Spacing Along Walls, m**

Wind Class	101 mm-core wall					152 mm-core wall					203 mm-core wall				
	Wall height (m)					Wall height (m)					Wall height (m)				
	2.4	2.7	3.0	3.3	3.6	2.4	2.7	3.0	3.3	3.6	2.4	2.7	3.0	3.3	3.6
N12 reo															
N2	1.8	1.8	1.8	1.6	1.4	1.8	1.8	1.8	1.8	1.8	1.8	1.8	1.8	1.8	1.8
N3	1.8	1.6	1.3	1.1	0.9	1.8	1.8	1.8	1.7	1.4	1.8	1.8	1.8	1.8	1.8
N4	1.3	1.1	0.9	0.7	0.6	1.8	1.7	1.4	1.1	0.9	1.8	1.8	1.8	1.5	1.3
N5	0.9	0.7	0.6	0.5	0.4	1.4	1.1	0.9	0.8	0.6	1.8	1.5	1.2	1.0	0.9
N6	0.7	0.5	0.4			1.1	0.8	0.7			1.4	1.1	0.9		
C1	1.5	1.2	0.9	0.8	0.7	1.8	1.8	1.5	1.2	1.0	1.8	1.8	1.8	1.7	1.4
C2	1.0	0.8	0.6	0.5	0.4	1.6	1.2	1.0	0.8	0.7	1.8	1.7	1.4	1.1	0.9
C3	0.7	0.5	0.4			1.1	0.8	0.7			1.4	1.1	0.9		
C4	0.5					0.8	0.6				1.1	0.8			
N16 reo															
N2	1.8	1.8	1.8	1.8	1.8	1.8	1.8	1.8	1.8	1.8	1.8	1.8	1.8	1.8	1.8
N3	1.8	1.8	1.8	1.8	1.5	1.8	1.8	1.8	1.8	1.8	1.8	1.8	1.8	1.8	1.8
N4	1.8	1.8	1.4	1.2	1.0	1.8	1.8	1.8	1.8	1.7	1.8	1.8	1.8	1.8	1.8
N5	1.5	1.2	1.0	0.8	0.7	1.8	1.8	1.6	1.3	1.1	1.8	1.8	1.8	1.8	1.6
N6	1.1	0.9	0.7	0.6	0.5	1.8	1.5	1.2	1.0	0.8	1.8	1.8	1.7	1.4	1.1
C1	1.8	1.8	1.6	1.3	1.1	1.8	1.8	1.8	1.8	1.8	1.8	1.8	1.8	1.8	1.8
C2	1.7	1.3	1.1	0.9	0.7	1.8	1.8	1.8	1.5	1.2	1.8	1.8	1.8	1.8	1.7
C3	1.1	0.9	0.7	0.6	0.5	1.8	1.5	1.2	1.0	0.8	1.8	1.8	1.7	1.4	1.1
C4	0.8	0.7	0.5	0.4		1.4	1.1	0.9	0.7	0.6	1.8	1.5	1.2	1.0	0.9

Notes

1. The tabulated values are the maximum spacing along the walls. They do not show the additional bars that are required adjacent to window, doors and other openings. Nor do they show the required horizontal reinforcement.
2. "Wind Class" refers to the wind classification of AS 4055. The ultimate pressure from AS 4055, upon which this design is based, are:

N2	0.96 kPa
N3	1.50 kPa
N4	2.23 kPa
N5	3.29 kPa
N6	4.44 kPa
C1	2.03 kPa
C2	3.01 kPa
C3	4.44 kPa
C4	5.99 kPa

Table 3.2.1 – Lintels
Maximum uniformly distributed load, adjusted for factored self weight, kN/m

Support Conditions & Load Direction	Core Width	Total depth	No of bars	Main reo	Opening Size								
					B	D	N	Reo	0.9	1.2	1.8	2.4	3.0
	mm	mm	-	-	m	m	M	m	m	m	m	m	m
Continuous (Uplift)	101	200	1	N12	5	4	3	3	2	2	2	1	1
	101	200	1	N16	6	5	4	3	3	2	2	1	1
	101	300	1	N12	41	28	16	10	7	6	4	4	3
	101	300	1	N16	48	42	27	17	12	9	7	6	5
	101	400	1	N12	60	41	23	15	11	8	6	5	4
	101	400	1	N16	68	58	40	26	18	14	11	9	7
	101	500	1	N12	79	54	30	20	14	11	8	7	6
	101	500	1	N16	88	75	53	34	24	18	14	11	9
	101	600	1	N12	98	67	38	25	17	13	10	8	7
	101	600	1	N16	107	92	66	43	30	22	17	14	12
Continuous (Uplift)	152	200	1	N12	6	5	4	4	3	2	2	2	1
	152	200	1	N16	7	6	5	4	4	3	2	2	2
	152	300	1	N12	42	29	17	11	8	6	5	4	3
	152	300	1	N16	52	45	28	18	13	10	8	6	5
	152	400	1	N12	61	42	24	16	11	9	7	6	5
	152	400	1	N16	73	63	42	27	19	14	11	9	8
	152	500	1	N12	80	55	31	21	15	11	9	7	6
	152	500	1	N16	94	81	55	36	25	19	15	12	10
	152	600	1	N12	99	68	39	25	18	14	11	9	8
	152	600	1	N16	116	99	68	44	31	23	18	15	12
Continuous (Uplift)	203	200	1	N12	7	7	5	4	3	3	2	2	2
	203	200	1	N16	9	8	6	5	5	4	3	3	2
	203	300	1	N12	43	30	17	11	8	6	5	4	4
	203	300	1	N16	56	48	29	19	14	10	8	7	6
	203	400	1	N12	62	43	25	16	12	9	7	6	5
	203	400	1	N16	79	68	43	28	20	15	12	10	8
	203	500	1	N12	81	56	32	21	15	12	9	8	7
	203	500	1	N16	101	87	56	36	26	20	15	13	11
	203	600	1	N12	100	69	40	26	19	14	12	10	8
	203	600	1	N16	124	107	69	45	32	24	19	16	13

Table 3.2.2 – Lintels
Maximum uniformly distributed load, adjusted for factored self weight, kN/m

Support Conditions & Load Direction	Core Width	Total depth	No of bars	Main reo	Opening Size								
					B	D	N	Reo	0.9	1.2	1.8	2.4	3.0
	mm	mm	-	-	m	m	m	m	m	m	m	m	m
Continuous (Down)	101	200	1	N12	5	4	3	2	2	1	1	1	1
	101	200	1	N16	7	5	4	3	2	2	1	1	1
	101	300	1	N12	35	23	12	7	4	3	2	1	1
	101	300	1	N16	42	35	19	11	7	5	4	3	2
	101	400	1	N12	58	38	19	12	8	5	4	3	2
	101	400	1	N16	76	61	33	20	13	9	7	5	4
	101	500	1	N12	81	52	27	16	11	7	5	4	3
	101	500	1	N16	123	91	48	29	19	14	10	8	6
	101	600	1	N12	103	67	35	21	14	9	7	5	4
	101	600	1	N16	181	118	62	38	25	18	13	10	8
Continuous (Down)	152	200	1	N12	7	6	4	3	2	2	1	1	0
	152	200	1	N16	8	7	5	4	3	2	2	2	1
	152	300	1	N12	36	23	12	7	4	3	2	1	1
	152	300	1	N16	45	37	20	12	8	5	4	3	2
	152	400	1	N12	59	38	19	11	7	5	3	2	1
	152	400	1	N16	81	65	34	21	13	9	7	5	4
	152	500	1	N12	81	53	27	16	10	7	5	3	2
	152	500	1	N16	131	93	48	29	19	13	10	7	5
	152	600	1	N12	104	67	34	20	13	9	6	4	3
	152	600	1	N16	185	120	63	38	25	17	13	9	7
Continuous (Down)	203	200	1	N12	8	7	5	4	2	1	1	0	0
	203	200	1	N16	10	8	6	4	3	3	2	1	1
	203	300	1	N12	36	23	11	6	4	2	1	1	0
	203	300	1	N16	47	39	20	12	8	5	3	2	1
	203	400	1	N12	59	38	19	11	7	4	3	1	1
	203	400	1	N16	86	67	34	20	13	9	6	4	3
	203	500	1	N12	81	52	26	15	9	6	4	2	1
	203	500	1	N16	139	94	48	29	19	13	9	6	5
	203	600	1	N12	104	67	34	20	12	8	5	3	2
	203	600	1	N16	186	121	62	37	24	17	12	9	6

Table 3.2.3 – Lintels													
Maximum uniformly distributed load, adjusted for factored self weight, kN/m													
Support Conditions & Load Direction	Core Width	Total depth	No of bars	Main reo	Opening Size								
	B	D	N	Reo	0.9	1.2	1.8	2.4	3.0	3.6	4.2	4.8	5.4
	mm	mm	-	-	m	m	M	m	m	m	m	m	m
Simple Support (Uplift)	101	200	1	N12	5	4	3	3	2	2	1	1	1
	101	200	1	N16	6	5	4	3	2	2	1	1	1
	101	300	1	N12	33	23	13	8	6	5	4	3	3
	101	300	1	N16	48	38	22	14	10	7	6	5	4
	101	400	1	N12	48	33	19	12	9	7	5	4	4
	101	400	1	N16	68	57	32	21	15	11	9	7	6
	101	500	1	N12	63	43	25	16	11	9	7	6	5
	101	500	1	N16	88	75	43	28	19	15	11	9	8
	101	600	1	N12	78	54	30	20	14	11	8	7	6
	101	600	1	N16	107	92	53	34	24	18	14	11	9
Simple Support (Uplift)	152	200	1	N12	6	5	4	3	2	2	2	1	1
	152	200	1	N16	7	6	5	4	3	2	2	2	2
	152	300	1	N12	34	23	13	9	6	5	4	3	3
	152	300	1	N16	52	41	23	15	11	8	6	5	4
	152	400	1	N12	49	34	19	13	9	7	6	5	4
	152	400	1	N16	73	60	34	22	16	12	9	8	6
	152	500	1	N12	65	45	25	17	12	9	7	6	5
	152	500	1	N16	94	78	44	29	20	15	12	10	8
	152	600	1	N12	80	55	31	21	15	11	9	8	7
	152	600	1	N16	116	97	55	36	25	19	15	12	10
Simple Support (Uplift)	203	200	1	N12	7	7	5	4	3	2	2	2	2
	203	200	1	N16	9	8	6	5	4	3	3	2	2
	203	300	1	N12	35	24	14	9	7	5	4	4	3
	203	300	1	N16	56	42	24	16	11	9	7	6	5
	203	400	1	N12	50	35	20	13	10	8	6	5	5
	203	400	1	N16	79	61	35	23	16	12	10	8	7
	203	500	1	N12	65	45	26	17	13	10	8	7	6
	203	500	1	N16	101	80	45	30	21	16	13	10	9
	203	600	1	N12	81	56	32	21	16	12	10	8	7
	203	600	1	N16	124	99	56	37	26	20	16	13	11

Table 3.2.4 – Lintels
Maximum uniformly distributed load, adjusted for factored self weight, kN/m

Support Conditions & Load Direction	Core Width	Total depth	No of bars	Main reo	Opening Size								
	B	D	N	Reo	0.9	1.2	1.8	2.4	3.0	3.6	4.2	4.8	5.4
	mm	mm	-	-	m	m	m	m	m	m	m	m	m
Simple Support (Down)	101	200	1	N12	5	4	3	2	2	1	1	1	0
	101	200	1	N16	7	5	4	3	2	2	1	1	0
	101	300	1	N12	28	18	9	5	3	2	1	1	1
	101	300	1	N16	42	29	15	9	6	4	3	2	1
	101	400	1	N12	46	30	15	9	6	4	3	2	1
	101	400	1	N16	76	51	26	16	11	7	5	4	3
	101	500	1	N12	64	42	21	13	8	6	4	3	2
	101	500	1	N16	112	73	38	23	15	11	8	6	4
	101	600	1	N12	82	53	28	16	11	7	5	4	3
	101	600	1	N16	145	94	49	30	20	14	10	8	6
Simple Support (Down)	152	200	1	N12	7	6	4	3	2	1	1	0	0
	152	200	1	N16	8	7	5	4	3	2	2	1	1
	152	300	1	N12	28	18	9	5	3	2	1	1	0
	152	300	1	N16	45	31	16	9	6	4	3	2	1
	152	400	1	N12	46	30	15	9	5	3	2	1	1
	152	400	1	N16	81	53	27	16	10	7	5	3	2
	152	500	1	N12	65	42	21	12	8	5	3	2	1
	152	500	1	N16	114	74	38	23	15	10	7	5	4
	152	600	1	N12	83	53	27	16	10	6	4	3	2
	152	600	1	N16	147	96	49	30	19	13	9	7	5
Simple Support (Down)	203	200	1	N12	8	7	5	3	2	1	0	0	0
	203	200	1	N16	10	8	6	4	3	2	1	1	0
	203	300	1	N12	28	18	9	5	3	1	1	0	0
	203	300	1	N16	47	32	16	9	6	4	2	1	1
	203	400	1	N12	46	30	15	8	5	3	2	1	0
	203	400	1	N16	82	53	27	16	10	7	4	3	2
	203	500	1	N12	64	41	20	12	7	4	2	1	0
	203	500	1	N16	115	74	38	23	14	10	7	5	3
	203	600	1	N12	82	53	26	15	9	6	3	2	1
	203	600	1	N16	148	96	49	29	19	13	9	6	4

4. Fire Performance

Building Code of Australia Requirements

BCA Volume 1 Part C defines the fire resistance requirements for Class 2 to 9 buildings.

BCA Volume 2 Part 3.7.1 defines the fire resistance requirements for Class 1 and 10a buildings.

The precise quantified requirements should be determined from the relevant parts of the BCA, but may be summarized generally as requiring:

- Structural adequacy (resistance to collapse), when subject to fire
- Integrity (resistance to the passage of flame and hot gasses), when subject to fire
- Insulation (resistance to the passage of heat), when subject to fire
- Resistance to the spread of flame
- Resistance to the generation and spread of smoke

General Comments

1. When an Eco-Block wall is subjected to a fire test, the exposed surface of rendered polystyrene melts away and is consumed by the fire, leaving the concrete core exposed. Depending on the thickness of the concrete and the quantity and disposition of the steel reinforcement. The concrete core will exhibit structural adequacy/integrity/insulation similar to other reinforced concrete structures.
 - For concrete cores complying with the reinforcement requirements of AS 3600 (i.e. close spaced reinforcement), the fire resistance levels (FRLs) may be determined in accordance with AS 3600.
 - For concrete cores not complying with the reinforcement requirements of AS 3600 (i.e. wide- spaced reinforcement), the fire resistance levels (FRLs) must be determined by test in accordance with AS 1530.4. These tests are not currently available.
2. In the systems tested (i.e. with 13 mm gypsum plasterboard fixed to the surface), the rendered polystyrene melted away without sustaining or spreading flame and without the generation of an excessive amount of smoke. Compliance with the BCA requirements for Spread of Flame and Smoke Generation must be established by reference to BCA Volume 1 Specification C1.10(a) test to AS ISO 9705.

Fire Performance of Commercial / Industrial Eco-Block Wall Systems (Eco-Block 230 CI, Eco-Block 280 CI and Eco-Block 330 CI)

Some Eco-Block systems have been tested in the United States against ASTM standards, and opinions provided by BRANZ in relation to the appropriate FRLs (Fire Resistance Levels) for Australian applications. An index to the appropriate test reports are included in Appendix 4. When constructed with close-spaced reinforcement in accordance “Eco-Block Australia Wall System Technical Manual”, September 2008, the system will provide the following fire resistance.

System	Thickness of concrete core Mm	Fire Resistance Levels Structural / Integrity / Insulation mins / mins /mins
Eco-Block 230 CI	101	90/90/90
Eco-Block 280 CI	152	180/180/180
Eco-Block 330 CI	203	240/240/240
Walls must be supported top and bottom, and be designed in accordance with AS 3600.		

Important Note

The following tables do not apply to Detached, Duplex and Some Grouped Residential Eco-Block Wall Systems (Eco-Block 230, Eco-Block 280 and Eco-Block 330), which have wide-spaced reinforcement. These systems are likely to exhibit similar properties, but their fire performance has not yet been demonstrated by fire test.

Standard Fire Test for Walls

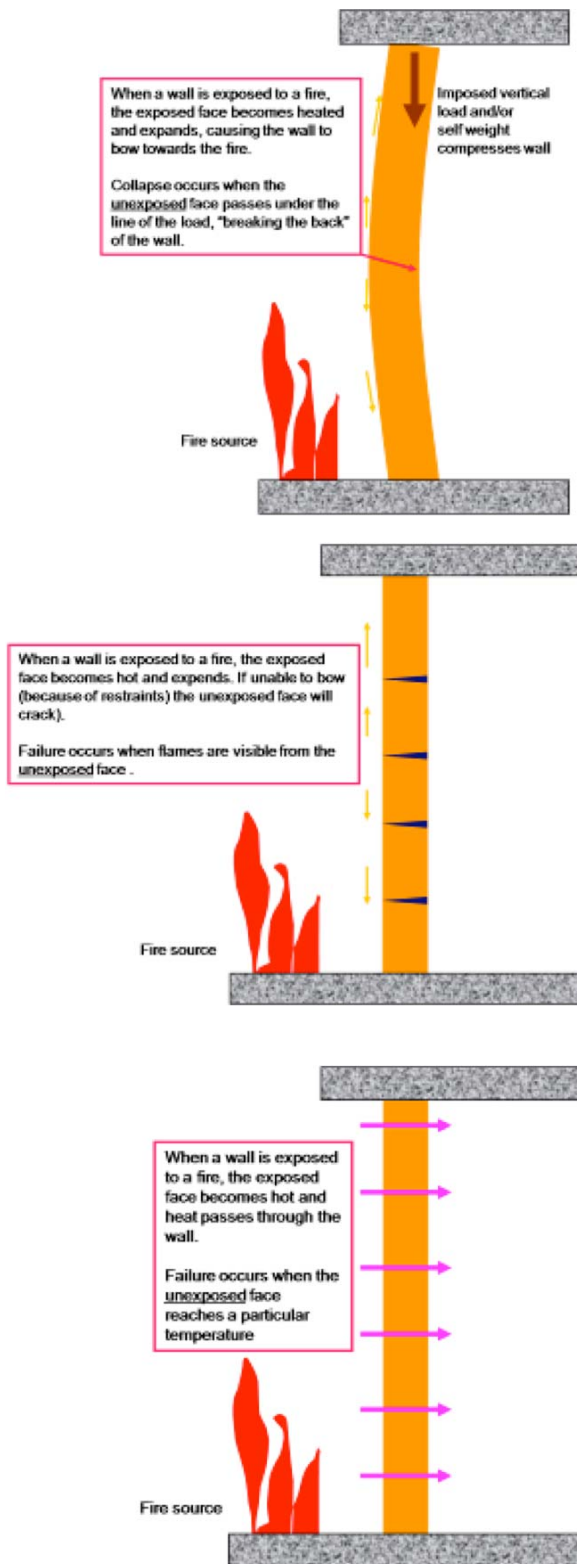

The Fire Resistance Level (FRL) for Structural Adequacy is the ability of a wall to remain stable when exposed to fire. Structural Adequacy is a function of:

- Thermal expansion of the material
- Slenderness (affected by thickness, vertical span and horizontal span between supports)

Fire Test to AS 1530.4

- The material properties may be determined from fire tests to AS 1530.4.
- This information may be then interpreted using the formulae given in AS 3700 or similar standards to predict wall behaviour.

Wall panels may be supported at the top and bottom and subjected to an applied load. This is known as a "loadbearing test". Alternatively the panels may be supported on one side and not subjected to any externally applied load. This is known as a "non-loadbearing test". The terminology is a little misleading, since experience has shown that collapse of a wall (structural adequacy failure) is more influenced by the number of sides supported and the corresponding wall slenderness than by the magnitude of this applied vertical load. A more informative description would be "test with supports at top and bottom" and "test with supports on four sides".

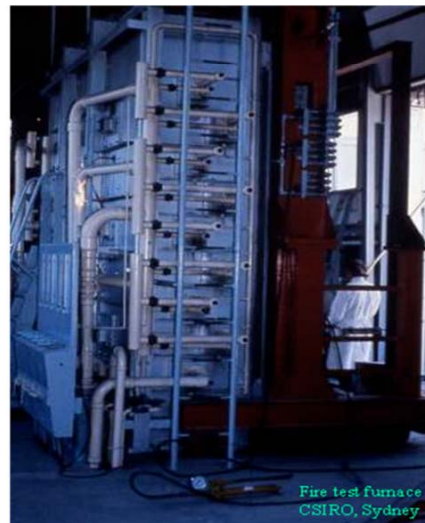
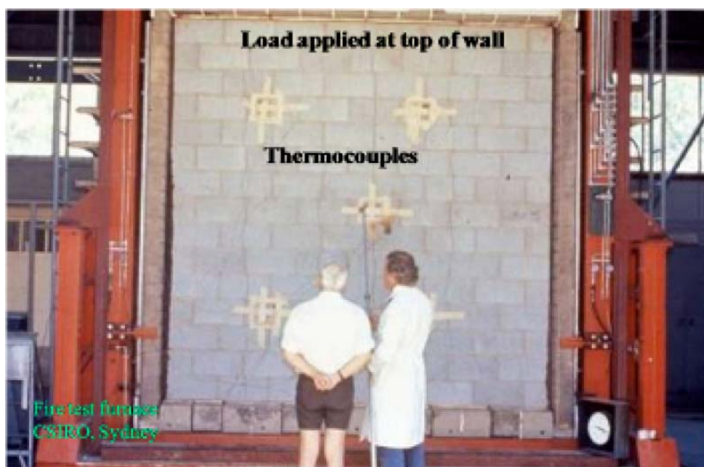

The standard fire test in AS 1530.4 uses the same three failure criteria, mentioned in the BCA and AS 3700, of structural adequacy, integrity and insulation.

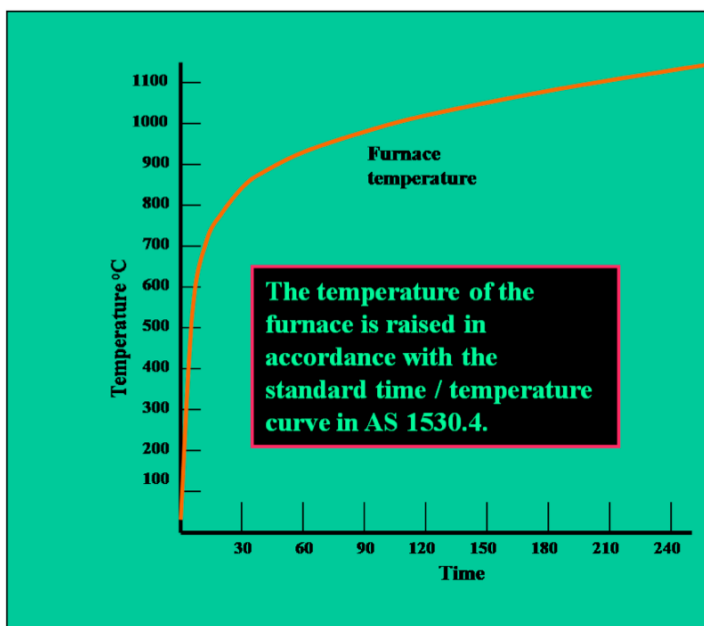

5. Acoustic Performance

When sound impinges on a wall, it may be reflected or absorbed.

- Reflected sound may manifest in a room as undesirable echoes, and may be controlled by a variety of techniques, including surface treatment.
- Absorbed sound may be dissipated within the wall, transmitted through or radiated through wall vibration. The polystyrene forms play a major part in this process.

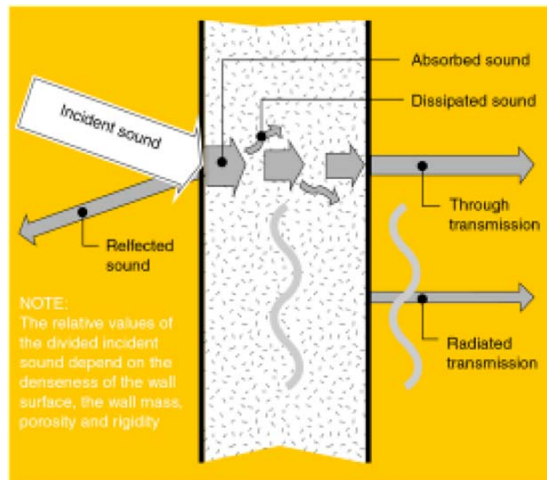

There are three distinct modes of sound transmission through walls:

1. Below the resonant frequency, the stiffness of the wall is of greatest importance, and the mass and damping have little effect. As the frequency increases, the mass of the wall becomes more important and the wall begins to resonate.
2. Beyond resonance, the mass of the wall provides a damping effect, and “high mass” systems have an advantage over lightweight alternatives. The resistance to sound transmission increases by approximately 6 dB for each doubling of the frequency or for each doubling of the mass.
3. Above the critical frequency, the coincidence of the sound waves control the behaviour. The critical frequency for heavy wall systems is relatively low. A coincidence dip immediately above the critical frequency indicates a loss in airborne sound resistance.

Impact Sound Resistance

When bedrooms or other quiet areas are adjacent to bathrooms, kitchens and the like, it is important to reduce the sound transmitted through the wall as a result of a blow to the other side of the wall or attached furniture. The impact sound resistance of a wall is measured by generating noise with a machine having multiple steel hammers, which impact on a steel plate placed in contact with the wall. The sound passing through the wall may be measured in a manner similar to that used for airborne sound resistance.

Resistance to impact sound requires properties different from those for resistance to airborne sound. A dense stiff material will vibrate when it is struck, while a soft material will simply absorb the blow without transmitting it. For example, hard dense plaster or render has a lower impact sound resistance than the softer commercially available plasterboards. Soft or resilient polystyrene material of the forms will significantly reduce the amount of impact that is transmitted.

Weighted Sound Index, R_w

Weighted Sound Index (R_w) for laboratory measurements is defined in AS/NZS 1276.1 (based on ISO 717-1) and ISO 140.3. R_w is determined by comparing the set of laboratory test sample transmission losses against a set of reference data obtained from ISO 717-1 for the sixteen one-third octave bands between 100 Hz and 3150 Hz. The reference data is amplitude shifted in steps of 1 dB by the same amount until the sum of unfavourable readings determined at each frequency is as large as possible, but not more than 32 Hz. R_w is equal to the 500 Hz value of the reference data less the number of decibels that the reference data was shifted.

Sound Transmission Class, STC

Sound Transmission Class (STC), based on an ASTM test, has previously been used to define a wall's ability to resist the transmission of airborne sound. The Building Code of Australia now defines sound attenuation performance criteria in terms of the ISO based Weighted Sound Index (R_w). In practical terms, there is little difference between the two for heavy wall material.

Spectrum Adaptation Terms, C and C_{tr}

There are some sources of sound, such as urban traffic noise, that are not well accommodated by the weighted index, R_w . The Spectrum Adaptation Term (C_{tr}) has been introduced to further describe the performance of a wall when subjected to sound likely to originate from A-weighted urban traffic noise. The Spectrum Adaptation Term (C) may also be used to describe the response to A-weighted "pink" noise. The Spectrum Adaptation Terms (C and C_{tr}) are defined in AS/NZS 1276.1 (based on ISO 717-1). Both C and C_{tr} have negative values, such that when they are added to the R_w , they diminish the combined value. Therefore relatively small values for C and C_{tr} indicate good overall performance whilst large values indicate a deterioration of performance at low frequencies. Typically heavy walls will have values in the ranges:

C	-1 to -2
C_{tr}	-3 to -10.

Weighted Standardised Level Difference, $D_{nT,w}$

Weighted Standardised Level Difference ($D_{nT,w}$), for field measurements is defined in AS/NZS 1276.1 (based on ISO 717-1) and ISO 140-4 in a manner similar to that used for Weighted Sound Index (R_w). Previously Field Sound Transmission Class (FSTC), based on an ASTM test procedure, has been used to define a wall's ability to resist the transmission of airborne sound in the constructed building. However, the Building Code of Australia now defines its performance requirements in terms of the ISO based Weighted Standardised Level Difference ($D_{nT,w}$).

Weighted Standardised Impact Sound Pressure Level, $L_{nT,w}$

The Weighted Standardised Impact Sound Pressure Level ($L_{nT,w}$) for measurements of impact resistance is defined in AS/NZS 717-1. The Building Code of Australia also makes provision for the determination of comparative resistance of walls to impact sound using AS 1191 and ISO 140/6.

References

AS 1191 Acoustics – Methods for laboratory measurement of airborne sound insulation of building elements

AS/NZS 1276.1.1 Acoustics – Rating of sound insulation in buildings and building elements Part 1 – Airborne sound insulation

ISO 140.6E Acoustics – Measurement of sound insulation in buildings and of building elements Part 6 – Laboratory measurements of impact sound insulation of floors

ISO 717.1 Acoustics – Rating of sound insulation in buildings and of building elements Part 1 – Airborne sound insulation

BCA Vol 1 Clause F5.5 Requirements

- Walls that separate sole occupancy units in a Class 2 or 3 building or between two Class 1 buildings
 - $R_w + C_{tr}$ (airborne) not less than 50, and
 - Impact sound resistance, if the wall separates a habitable room in one sole occupancy unit from a bathroom, sanitary compartment, laundry or kitchen of another unit or plant room or lift shaft).
- Walls that separate a sole occupancy unit from a plant room, lift shaft, stairway, public corridor, public lobby or the like in a Class 2 or 3 building:
 - R_w (airborne) not less than 50, and
 - Impact sound resistance, if the wall separates a habitable room in one sole occupancy unit from a plant room, or lift shaft.
- Walls that separates two sole occupancy units or separates a sole occupancy unit from a kitchen, bathroom, sanitary compartment (not en-suite), laundry, plant room or utilities room in a Class 9c aged-care building
 - R_w (airborne) not less than 45, and
 - Impact sound resistance if the wall separates a habitable room in one sole occupancy unit from a kitchen or laundry.
- A door incorporated in a wall that separates a sole occupancy unit from stairway, public corridor, public lobby or the like in a Class 2 or 3 building and a door incorporated in a wall that separates a sole occupancy unit from a kitchen or laundry in a Class 9c aged care building.
 - R_w (airborne) not less than 30.

Walls requiring impact sound resistance shall consist of two leaves separated by a gap of at least 20 mm (and in Class 2 or 3 where required, connected by resilient ties).

BCA Vol 2 Clauses 3.8.6.1 to 3.8.6.4 Requirements

- Walls that separate a bathroom, sanitary compartment, laundry or kitchen of one Class 1 building from a habitable room (other than a kitchen) in an adjoining Class 1 building (dwelling) shall have:
 - $R_w + C_{tr}$ (airborne) not less than 50 and
 - Discontinuous construction. For cavity walls, a minimum of 20 mm cavity between two separate leaves, which may be connected, if required for structural purposes, with resilient ties. Northern Territory, Queensland and Western Australia have varied this requirement to R_w not less than 50 and Impact Sound Resistance.
- Walls are required to be detailed in accordance with BCA Vol 2 Clause 3.8.6.3, which make provision for the sealing of sound insulated walls at junctions with perimeter wall and roof cladding. This clause provides for sound insulated articulation joints. BCA Vol 2 Clause 3.8.6.4 makes provision for services in sound insulated walls.
- Walls required to have a sound insulation shall be constructed to the underside of:
 - a floor above
 - a ceiling with the same acoustic rating
 - a roof above.

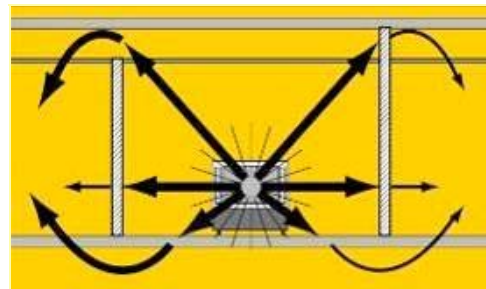

Effect of Joints and Gaps

Gaps reduce the sound attenuation of a wall. Laboratory tested walls have full joints. Gaps around the vertical edges of a wall and at the ceiling will diminish the sound resistance of a wall. A gap 0.1% of wall area (corresponding to a 3 mm gap along the length of a 3 m high wall) can reduce the sound transmission resistance by typically 10-20 dB. Gaps around the periphery of walls should be sealed using a high-density acoustically-rated mastic or similar sealant. Sealants should have a typical density of 1600 kg/m³. Sealants should be applied to both faces of the wall and should be applied to a depth equal to the width of the gap. Typical penetrations in walls include mechanical services ducts, refrigerant pipes, hydraulic reticulation lines, waste pipes and fire sprinklers and electrical cables. It is essential to provide an acoustically rated seal around the penetration.

Surface Treatment

Render may be applied to the Eco-Block Wall System to assist in achieving required sound attenuation, but should be applied full-height, from floor slab to soffit.

Chases

Chases in walls diminish the sound attenuation. Chases should not extend deeper than 25mm into the wall. All chases should be rendered over after the pipes or cables are installed.

Acoustic Performance of Eco-Block Wall System

Tests

Field tests have been carried out by Palmer Acoustics (Aust) Pty Ltd, and provide the source of the following information and opinion. Refer to Appendix E for details of the tests.

Airborne Sound Transmission Reduction

Based on the following field tests by Palmer Acoustics (Aust) Pty Ltd, ECO 280 (152 mm concrete core) has a predicted airborne sound transmission reduction in excess of $R_w + C_{tr}$ (airborne) of 50.

Airborne Sound Transmission Field Test Results			
System	FSTC	D_{nt,w}	C_{tr}
Test No 1 ECO 280 (152 mm concrete core) 19 Beale Street, Southport Qld	54	56	-4
Test No 2 ECO 280 (152 mm concrete core) 19 Beale Street, Southport Qld	54	56	-5
Field measurement D _{nt,w} closely approximates laboratory measurements of R _w FSTC term is in accordance with ASTM E413 D _{nt,w} and C _{tr} spectrum adaptation terms are in accordance with AS 1276 as defined in ISO 717-1			

Impact Sound Transmission Reduction

Palmer also provides the following expert opinion in respect of impact resistance.

Based upon our understanding of the system, experience with wall impact noise in many high rise residential buildings and as a practicing Acoustic Engineer (RPEQ, CPEng, NPER 3) I certify that the proposed system meets the BCA requirement to be sufficient to prevent illness or loss of amenity to the occupants, with regard to the isolation of impact noise. In this application the two 65mm thick polystyrene formwork panels serve to act as impact isolation elements serving to sufficiently decouple impact noise across the wall.

6. Thermal Performance

Factors Affecting Thermal Efficiency

The main factors influencing good solar design are as follows:

- Adequate solar access in cold climates. The building should be oriented such that the warmth can be harnessed in winter, and cooling breezes captured in summer.
- For warm areas, large eaves, verandas, sun-shades and heavy curtains prevent sunshine from entering and overheating a building during hot weather. Good ventilation and light-coloured roofs assist the summer cooling process.
- For temperate and cool areas, north-facing windows permit the entry of winter sun, while correctly proportioned eaves restrict the entry of summer sun. Properly sealed doors and windows allow cross-ventilation in summer and restrict air and heat leakage in winter.
- The inclusion of roof and ceiling insulation, together with high thermal resistance of the Eco-Block wall system, will limit heat flows to and from the building.
- The thermal mass of tiled roofs, Eco-Block Wall System walls and concrete floors will act as a dampener to heat flows.

Thermal Performance – Heat Transfer

Heat transfers through the fabric of a building by a combination of:

- Conduction
- Convection
- Radiation.



Thermal Mass

If a building with high thermal mass experiences a heating and cooling cycle which crosses the comfort zone, the roof, walls and floor will store the heat energy for an extended period, gradually releasing it over time. In winter, high thermal mass buildings will remain relatively warm, while in summer, they will remain relatively cool.

In winter, heat trying to pass through the wall will become trapped in the wall and part will slowly pass back into the room. In summer the reverse occurs. Heat trying to pass through the wall from the outside will become trapped in the wall and part will slowly pass back out of the building. The thermal mass of the member (wall, roof/ceiling, floor etc) is the combination of the properties of each of the components and is a function of the mass and specific heat.

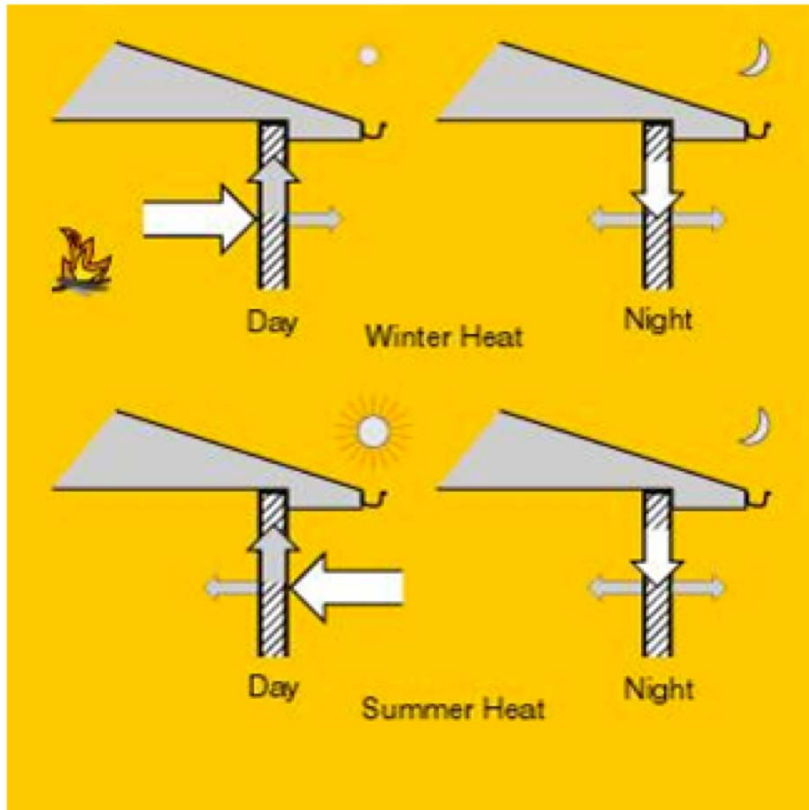

Thermal Resistance of Eco-Block Wall Systems		
Material	Thickness mm	Thermal resistance, R m ² .K/W
Eco-Block 230 Series – Concrete 101 mm		
External air film	-	0.03
External render	-	0.01
64 mm expanded polystyrene	64	1.60
101 mm reinforced concrete	101	0.07
64 mm expanded polystyrene	64	1.60
10 mm gypsum plasterboard	10	0.06
Internal air film	-	0.12
Total	239	3.49
Eco-Block 280 Series – Concrete 152 mm		
External air film	-	0.03
External render	-	0.01
64 mm expanded polystyrene	64	1.60
152 mm reinforced concrete	152	0.11
64 mm expanded polystyrene	64	1.60
10 mm gypsum plasterboard	10	0.06
Internal air film	-	0.12
Total	290	3.53
Eco-Block 330 Series – Concrete 203 mm		
External air film	-	0.03
External render	-	0.01
64 mm expanded polystyrene	64	1.60
152 mm reinforced concrete	203	0.14
64 mm expanded polystyrene	64	1.60
10 mm gypsum plasterboard	10	0.06
Internal air film	-	0.12
Total	341	3.56
Notes		
This table provides the thermal resistance of Eco-Block Wall System single leaf walls with 10 mm gypsum plasterboard lining, and without added insulation.		
The thermal resistances of Eco-Block Wall Systems are based on:		
<ul style="list-style-type: none"> • Class H expanded polystyrene, in accordance with AS 1366.3-1992, minimum thermal conductivity, k, of 0.0400 W/m.K • Reinforced concrete thermal conductivity, k, of 1.44 W/m.K • Gypsum plasterboard thermal conductivity, k, of 0.170 W/m.K • Internal and external air film thermal resistances, R = 0.03 and 0.12 m².K/W, in accordance with the Building Code of Australia. • The thermal resistance of the external render, R = 0.01, in accordance with the following report in Appendix F. Willrath, H., <i>Thermal Properties of Eco-Block</i>, Solar Logic, 20/9/05. 		
The thermal resistances tabulated herein are minimum expected values, based principally on the minima specified in AS 1366.3-1992 for Class H expanded polystyrene. These are less than (and therefore more conservative than) the values reported in Willrath, H., <i>Thermal Properties of Eco-Block</i> , Solar Logic, 20/9/05.		

7. Detailing

Introduction

All buildings are required to be built such that:

- The assumed support for walls (and other members) can be achieved, to resist gravity, wind, earthquake, and other loads;
- The building is weatherproof;
- The structure is durable, able to resist salts or any other expected corrosive materials.

Structural Supports

The connections and supporting structure must have sufficient combined capacity to transmit the horizontal in-plane and out-of-plane loads from the wall to the supports. They must also be such that the assumed action of the wall panel can be achieved. For example, if two-way action has been assumed, the connections at the top, bottom and each side must be consistent with the assumed support configuration. For top, base and sides, the connection capacities may be provided by a combination of:

- Steel Starter Bars, set in concrete slabs or columns; and/or
- Other Connectors, such as proprietary ties.

Weather-Proofing

Buildings must be constructed such that they are weather proof by the following means.

Walls must not crack

Notwithstanding the fact that walls constructed of Eco-Block Wall System are impervious to moisture penetration, it is necessary to ensure that the walls are properly supported on footings or other structures, which have adequate strength and stiffness to limit movement that would cause the Eco-Block Wall System to crack. Such movement generally results from foundation expansion or contraction, thermal expansion and contraction, wind, earthquake or imposed loads.

Moisture movements in clay or similar soils result in expansion and contraction, causing the building to either “hog” or “sag”. Trees roots suck the moisture out of the soil causing it to shrink. Poor or badly maintained drainage systems allow a build up of moisture in the soil causing it to expand.

The incorporation of reinforcement into Eco-Block Wall System walls will assist resistance to cacking in the most extreme cases of foundation movement.

Buildings should be regularly maintained, to ensure that:

- Trees have not grown too close to the footings;
- The plumbing system does not leak; and
- The stormwater drainage system effectively removes rainwater

Flashings

Attention to detail is important.

- Building must be correctly detailed to account for weatherproofing requirements, foundation movement, shrinkage and the efficient removal of rain water.
- Gutters and rainwater downpipes must be regularly inspected and kept clean, free of corrosion, and connected to a functioning stormwater system.
- Flashing must be secured and joints sealed with flexible sealant (e.g. silicone or similar), which should be renewed over time as they deteriorate.

Durability

Concrete which protects reinforcement must have sufficient cement content to create an alkaline environment which lasts the duration of the design life. AS 3700 Appendix E provides performance requirements for built-in components and deemed-to-comply corrosion resistance of galvanising and other treatments.

Built-in components should be galvanized to the required thicknesses. In aggressive environments, they should be manufactured from stainless steel or other non-corrosive materials in accordance with AS/NZS 2699.2 as appropriate.

Testing criteria for components in categories R0 to R4 are quite severe:

- (a) Maximum temperature of 55°C or 40°C if the component is embedded.
- (b) Daily temperature cycles from ambient (18°C) to 40°C.
- (c) The medium surrounding the accessory being initially alkaline pH up to 10 but reducing over time to become not less than 10 (i.e. close to neutral).
- (d) Remaining wet for a 3 month period.
- (e) Aerosol penetration to an extent depending on distance from the coast:
 - R0 - Nil
 - R1 - 10 g/m²/day
 - R2 - 20 g/m²/day
 - R3 - 60 g/m²/day
 - R4 - 300 g/m²/day
- (f) Exposure to ultra-violet radiation of 20 MJ/m² for a period of up to 4 weeks corresponding to the period of construction.

8. Specifications

Introduction

The building design and construction process involves three principle functions:

- Design, including product selection;
- Manufacture and supply of all components; and
- Construction, including the attendant supervision, inspections and certification.

Design

The design process must encompass the selection of the appropriate product for the particular design application. The Architect and Engineer for any building project share responsibility (and authority) to determine and communicate the design (within the constraints of Building Code of Australia) to the builders. They are required to consider all relevant matters affecting the building and its components, and determine their designs drawing on professional training, experience, peer practices, ethics, client requirements, published standards, research and the like. Building Code of Australia DTS (Deemed-to-Satisfy) provisions play an important part in this decision making (and in many cases will be adopted by the Engineer or Architect), although there are also many cases where the Engineer or Architect may specify details that are different from these. This information is communicated to builders by Drawings and Specifications.

Manufacture and supply

There are two principal requirements of manufacturers.

- Ensure that the Company has a properly functioning Management System, capable of delivering consistent product and service to predetermined specifications. Substantial compliance with the provision of AS/NZS ISO 9001 is considered to be an indicator of such a properly functioning system.
- Ensure that the nominated products satisfy the requirements of nominated Building Code of Australia clauses.

Construction

The construction process must faithfully ensure that the design expectations have been met, and that the product has been installed in accordance with the manufacturer's instructions. However, the Builder and the Contractors must assume responsibility for the quality of the construction work.

Designers often take it for granted that builders and tradesmen understand the detailed requirements for the construction of good quality buildings. This is not so - They need to be clearly guided by competent and informed designers.

Specification Template

Appendix H sets out a Specification Template for Eco-Block Wall System, also available in electronic format that may be adapted and edited for particular projects.²

² To download electronic specifications, click on www.electronicblueprint.com.au

9. Sustainability

Sustainability Policy

Eco-Block Australia is committed to encouraging the use of sustainable building products, with a view to:

- Reducing green-house gas generation, which causes global warming;
- Reducing the use of non-renewable resources upon which our society depends;
- Reducing land, water or air pollution or degradation, which alienates the use of these resources.

Appendix A Eco-Block Wall System Applications

For a full description of the Eco-Block applications, please refer to www.eco-blockaustralia



Simpler. Faster. Better.

ECO-Block Insulating Concrete Forms (ICFs) represent the superior way to build. ECO-Block is simpler and easier to install than wood-frame methods — and, even other ICF systems. It's faster, taking less time with fewer people. And it's better, because ECO-Block buildings are vastly more energy-efficient. Stronger. Quieter. Resistant to fire, moisture, mold and the elements. With a positive ecological impact.

Simpler

This state-of-the-art method of construction is also the simplest. ECO-Block insulating concrete forms are EPS (expanded polystyrene) panels that easily snap together to create walls of virtually any thickness, from 100mm on up in 50mm increments. The space between the panels is filled with concrete that cures and hardens into a monolithic, reinforced core of incredible strength.

No Limits To Design

ECO-Block gives you unlimited design flexibility. Got a saw? ECO-Block cuts easily into any shape you need — perfect for unique window openings and arches. You can also choose from our pre-formed corners in varying sizes and angles. And any exterior or interior finish can be directly applied to the panels.

- Build from the footing to the roofline, using one crew, one system.
- Form walls 100mm thick and greater in any configuration.
- Create any shape or contour your design calls for.
- Apply any exterior or interior finish.

Faster

The ECO-Block system gets the job done faster. With our multiple manufacturing locations throughout Australia, you save on transportation costs and delivery time. Because our flat panels can be packed tightly, ECO-Block is easier to ship and handle than other fixed-block ICFs.

Easy to Learn, Easy to Install

The ECO-Block system is easy to learn, requiring less time for training. Installing window and door openings is fast and simple with Universal Buck, the first field-engineered PVC buck system in the industry. ECO-Block's system of latching connectors snaps in place quickly, so ICF panels are joined together fast — and the job is done sooner. Only one construction crew is needed to get the job done,

instead of the typical three.

- Install window and door openings fast with Universal Buck.
- Train in less time with our easy-to-understand, integrated system.
- Assemble walls of any size quickly with easy-to-snap-in connectors.
- Electrical and plumbing installations are fast and easy.

Better

This is the better way to build, period. Energy savings generated by an ECO-Block building are enormous — and continue for the life of the building. You save on utility and maintenance costs. ECO-Block buildings stand strong against the wind and weather and will not warp over time. They can have up to a four-hour fire resistive rating. Many companies give discounts to ICF building owners for disaster and fire insurance.

- Significant energy savings.
- Reduced noise transmission.
- Will not support the growth of mold or mildew.
- Can be built to any seismic or hurricane-storm standard.
- Up to a four-hour Fire Resistive Rating.

Appendix B

Building Code of Australia Compliance

Scope

Detached, Duplex and Some Grouped Residential Eco-Block Wall Systems

Detached, Duplex and Some Grouped Residential Eco-Block Wall Systems (Eco-Block 230, Eco-Block 280 and Eco-Block 330) incorporate steel reinforcement at spacings that do not comply with AS 3600 *Concrete structures*. Therefore these systems must be treated, under the BCA³, as an Alternative Solution. The most relevant BCA referenced document is AS 3700 *Masonry structures*, which will be used as the comparison document.

Commercial / Industrial Eco-Block Wall Systems

Commercial / Industrial Eco-Block Wall Systems (Eco-Block 230 CI, Eco-Block 280 CI and Eco-Block 330 CI) incorporate steel reinforcement at spacings that do comply with AS 3600 *Concrete structures*. Therefore these systems may be treated as a Deemed-to-Satisfy solution under the BCA

Commercial / Industrial Eco-Block Wall Systems **Building Code of Australia Volume 1 (Class 2 – 9 Buildings)**

The following clauses of Building Code of Australia Volume 1 provide the criteria upon which this manual is based.

Clause A0.4 Compliance with the Building Code of Australia

Requirement

A Building Solution will comply with the Building Code of Australia if it satisfies the Performance Requirements

Application

In this case, the opinion is based on complying with this clause.

Clause A0.5 Meeting the Performance Requirements

Requirement

Compliance with the Performance Requirements can only be achieved by-

- (a) *complying with the Deemed-to-Satisfy Provisions; or*
- (b) *formulating an Alternative Solution, which:*
 - (i) *complies with the Performance requirements; or*
 - (ii) *is shown to be at least equivalent to the Deemed-to-Satisfy Provisions; or*
- (c) *a combination of (a) and (b)*

Application

In this case, the opinion is based on:

- (a) *complying with the Deemed-to-Satisfy Provisions for structural and fire considerations; and*
- (b) *formulating an Alternative Solution, which:*
 - (i) *complies with the Performance requirements; or*
 - (ii) *is shown to be at least equivalent to the Deemed-to-Satisfy Provisions; for energy efficiency and weatherproofing*

³ Building Code of Australia

Clause A0.8 Meeting the Performance Requirement

Requirement

- (a) *An Alternative Solution must be assessed according to one or more of the Assessment Methods.*
- (b) *An Alternative Solution will only comply with the Building Code of Australia if the Assessment Methods used to determine compliance with the Performance Requirements have been satisfied.*
- (c) *The Performance Requirements relevant to an Alternative Solution must be determined in accordance with A0.10.*

Application

In this case, the opinion is based on the Alternate Solutions complying fully with this clause.

Clause A0.9 Assessment Methods

Requirement

The following Assessment Methods, or any combination of them, can be used to determine that a Building Solution complies with the Performance Requirements:

- (a) *Evidence to support that the use of a material, form of construction or design meets a Performance Requirement or a Deemed-to-Satisfy Provision as described in A2.2.*
- (b) *Verification Methods such as—*
 - (i) *the Verification Methods in the Building Code of Australia; or*
 - (ii) *such other Verification Methods as the appropriate authority accepts for determining compliance with the Performance Requirements.*
- (c) *Comparison with the Deemed-to-Satisfy Provisions.*
- (d) *Expert Judgment.*

Application

In this case, the opinion is based on compliance with paragraphs:

- (a) *Evidence to support that the use of a material, form of construction or design meets a Performance Requirement or a Deemed-to-Satisfy Provision as described in A2.2.*
- (b) *Verification Methods such as—*
 - (i) *the Verification Methods in the Building Code of Australia; or*
 - (ii) *such other Verification Methods as the appropriate authority accepts for determining compliance with the Performance Requirements.*
- (c) *Comparison with the Deemed-to-Satisfy Provisions.*

Clause A0.10 Relevant Performance Requirements

Requirement

In order to comply with the provisions of A1.5 (to comply with Sections A to J inclusive) the following method must be used to determine the Performance Requirement or Performance Requirements relevant to the Alternative Solution:

- (a) *Identify the relevant Deemed-to-Satisfy Provision of each Section or Part that is to be the subject of the Alternative Solution.*
- (b) *Identify the Performance Requirements from the same Sections or Parts that are relevant to the identified Deemed-to-Satisfy Provisions.*
- (c) *Identify Performance Requirements from other Sections and Parts that are relevant to any aspects of the Alternative Solution proposed or that are affected by the application of the Deemed-to-Satisfy Provisions, that are the subject of the Alternative Solution.*

Application

In this case, the opinion is based on full compliance with this paragraph.

Clause A2.1 Suitability of materials

Requirement

Every part of a building must be constructed in an appropriate manner to achieve the requirements of the Building Code of Australia, using materials that are fit for purpose for which they are intended.

Application

In this case, the opinion is based on calculation that the Eco-Block Wall System satisfies this criterion.

Clause A2.2 Evidence of suitability

Requirement

- (a) *Subject to A2.3 and A2.4, evidence to support that the use of a material, form of construction or design meets a Performance Requirement or Deemed-to-Satisfy Provision may be in the form of one or a combination of the following:*
- (i) *A report issued by a Registered Testing Authority, showing that the material or form of construction has been submitted to the tests listed in the report, and setting out the results of those tests and any other relevant information that demonstrates its suitability for use in the building.....*
 - (iii) *A certificate from a professional engineer or other appropriately qualified person which-*
 - (A) *certifies that a material, design or form of construction complies with the requirements of the Building Code of Australia; and*
 - (B) *sets out the basis on which it is given and the extent to which relevant specification, rules, codes of practice or other publication have been relied upon.*
 - (iv) *A current certificate issued by a product certification body that has been accredited by the Joint Accreditation System of Australia and New Zealand (JAS-ANZ).....*

Application

In this case, the opinion is based on (a) (i), (iii) and (iv).

**Specification A1.3 Documents Adopted by Reference
Table 1 Schedule of Referenced Documents**

Application

The following referenced documents, called up in Building Code of Australia Vol 1-2007 Table 1, provide the source documents used to: *Identify the relevant Deemed-to-Satisfy Provision, Identify the Performance Requirements and Identify Performance Requirements from other Sections and Parts that are affected by the application of the Deemed-to-Satisfy Provisions*

AS 3600

Particular Criteria Relating to Building Code of Australia Volume 1 (Class 2 to 9 Buildings)

Section B - Structure

Performance Requirement

BP1.1

- (a) *A building or structure, to the degree necessary, must—*
- (i) *remain stable and not collapse; and*
 - (ii) *prevent progressive collapse; and*
 - (iii) *minimise local damage and loss of amenity through excessive deformation, vibration or degradation; and*
 - (iv) *avoid causing damage to other properties, by resisting the actions to which it may reasonably be subjected.*

BP1.2

The structural resistance of materials and forms of construction must be determined using five percentile characteristic material properties with appropriate allowance for—

- (a) *known construction activities; and*
- (b) *type of material; and*
- (c) *characteristics of the site; and*
- (d) *the degree of accuracy inherent in the methods used to assess the structural behaviour; and*
- (e) *action effects arising from the differential settlement of foundations, and from restrained dimensional changes due to temperature moisture, shrinkage, creep and similar effects.*

State Variations

Nil

Compliance

Compliance with these performance requirements is set out in Section 3 and Appendix C of this manual, based on AS 3600.

Section C - Fire Resistance

Performance Requirement

CP1

A building must have elements which will, to the degree necessary, maintain structural stability during a fire appropriate to—

- (a) *the function or use of the building; and*
- (b) *the fire load; and*
- (c) *the potential fire intensity; and*
- (d) *the fire hazard; and*
- (e) *the height of the building; and*
- (f) *its proximity to other property; and*
- (g) *any active fire safety systems installed in the building; and*
- (h) *the size of any fire compartment; and*
- (i) *fire brigade intervention; and*
- (j) *other elements they support; and*
- (k) *the evacuation time.*

CP2

- (a) *A building must have elements which will, to the degree necessary, avoid the spread of fire—*
- (i) *to exits; and*
 - (ii) *to sole-occupancy units and public corridors; and*
Application:
CP2(a)(ii) only applies to a Class 2 or 3 building or Class 4 part.
 - (iii) *between buildings; and*
 - (iv) *in a building.*
- (b) *Avoidance of the spread of fire referred to in (a) must be appropriate to—*
- (i) *the function or use of the building; and*
 - (ii) *the fire load; and*

- (iii) *the potential fire intensity; and*
- (iv) *the fire hazard; and*
- (v) *the number of storeys in the building, and*
- (vi) *its proximity to other property; and*
- (vii) *any active fire safety systems installed in the building; and*
- (viii) *the size of any fire compartment; and*
- (ix) *fire brigade intervention; and*
- (x) *other elements they support; and*
- (xi) *the evacuation time.*

CP3

A building must be protected from the spread of fire and smoke to allow sufficient time for orderly evacuation of the building in an emergency.

Application:

CP3 only applies to-

- (a) *a patient care area of a Class 9a health-care building; and*
- (b) *a Class 9c aged care building.*

CP4

A material and an assembly must, to the degree necessary, resist the spread of fire to limit the generation of smoke and heat, and any toxic gases likely to be produced, appropriate to—

- (a) *the evacuation time; and*
- (b) *the number, mobility and other characteristics of occupants; and*
- (c) *the function or use of the building; and*
- (d) *any active fire safety systems installed in the building.*

CP5

a concrete external wall that could collapse as a complete panel (e.g. tilt-up and pre-cast concrete) must be designed so that in the event of fire within the building the likelihood of outward collapse is avoided.

Limitation:

CP5 does not apply to a building having more than two storeys above ground level.

CP6

A building must have elements, which will, to the degree necessary~ avoid the spread of fire from service equipment having—

- (a) *a high fire hazard; or*
- (b) *a potential for explosion resulting from a high fire hazard.*

CP7

A building must have elements, which will, to the degree necessary, avoid the spread of fire so that emergency equipment provided in a building will continue to operate for a period of time necessary to ensure that the intended function, of the equipment is maintained during a fire.

State Variations

Nil

Compliance

Compliance with these performance requirements is set out in Section 4 and Appendix D of this manual, which incorporate the findings of BRANZ report and consideration of AS 3600.

Section F - Health and Amenity – Damp and WeatherproofingPerformance Requirement*FP1.4*

A roof and external wall (including openings around windows and doors) must prevent the penetration of water that could cause—

- (a) unhealthy or dangerous conditions, or loss of amenity for occupants; and
- (b) undue dampness or deterioration of building elements.

Limitation: FP1.4 does not apply to-

- (a) Class 7 or 8 buildings where in the particular case there is no necessity for compliance; or
- (b) a garage, tool shed, sanitary compartment or the like, forming a building used for other purposes; or
- (c) an open spectator stand or open-deck carpark.

State Variations

Nil

Compliance

Compliance with these performance requirements is set out in Section 7 and Appendix G of this manual.

Section F - Health and Amenity (Sound)Performance Requirement*FP5.2*

Walls separating sole-occupancy units or a sole-occupancy unit from a plant room, lift shaft, stairway, public corridor, public lobby, or the like, or parts of a different classification, must provide insulation against the transmission of—

- (a) airborne sound; and
- (b) impact generated sound, if the wall is separating a bathroom, sanitary compartment, laundry or kitchen in one sole-occupancy unit from a habitable room (other than a kitchen) in an adjoining unit, sufficient to prevent illness or loss of amenity to the occupants.

Application:.

FP5.2 only, applies to a Class 2 or 3 building.

FP5.5

Walls separating sole-occupancy units, or a sole-occupancy unit from a kitchen bathroom, sanitary compartment (not being an associated ensuite), laundry, plant room or utilities room, must provide insulation against the transmission of—

- (a) airborne sound; and
- (b) impact generated sound, if the wall separates a sole-occupancy unit from a kitchen or laundry,

sufficient to prevent illness or loss of amenity to the occupants.

Application

FP5.5 only applies to a Class 9c aged care building.

State Variations

Nil

Compliance

Compliance with these performance requirements is set out in Section 5 and Appendix E of this manual.

Section J Energy and EfficiencyRequirement**J1.5 (a) Walls**

Deemed-to-Satisfy Provisions from BCA Vol 1 J1.3.(a)

State Variations

In New South Wales BCA Volume 1 Section J is replaced by NSW Section J.

- *For Class 2 and Class 4 buildings, NSW BASIX applies in accordance with NSW Subsection JA.*
- *For Class 3, 5, 6, 7a, 7b, 9a, 9b and 9c buildings, BCA Volume 1 Section J, in accordance with NSW Subsection JB.*

In Northern Territory, BCA Volume 1 Section J does not apply.

In Victoria, there is a variation of the star requirements for JV1.

Compliance

Compliance with these performance requirements is set out in Section 6 and Appendix F of this manual.

Detached, Duplex and Some Grouped Residential Eco-Block Wall Systems Building Code of Australia Volume 2 (Class 1 and 10 Buildings)

The following clauses of Building Code of Australia Volume 2 provide the criteria upon which this manual is based.

Clause 1.0.4 Compliance with the Building Code of Australia

Requirement

A Building Solution will comply with the Building Code of Australia if it satisfies the Performance Requirements

Application

In this case, the opinion is based on complying with this clause.

Clause 1.0.5 Meeting the Performance Requirements

Requirement

Compliance with the Performance Requirements can only be achieved by-

- (a) *complying with the Deemed-to-Satisfy Provisions; or*
- (b) *formulating an Alternative Solution, which:*
 - (i) *complies with the Performance requirements; or*
 - (ii) *is shown to be at least equivalent to the Deemed-to-Satisfy Provisions; or*
- (c) *a combination of (a) and (b)*

Application

In this case, the opinion is based on:

- (b) *formulating an Alternative Solution, which:*
 - (i) *complies with the Performance requirements; or*
 - (ii) *is shown to be at least equivalent to the Deemed-to-Satisfy Provisions; or*

Clause 1.0.8 Alternative Solutions

Requirement

- (a) *An Alternative Solution must be assessed according to one or more of the Assessment Methods.*
- (b) *An Alternative Solution will only comply with the Building Code of Australia if the Assessment Methods used to determine compliance with the Performance Requirements have been satisfied.*
- (c) *The Performance Requirements relevant to an Alternative Solution must be determined in accordance with 1.0.10.*

Application

In this case, the opinion is based on the Alternate Solutions complying fully with this clause.

Clause 1.0.9 Assessment Methods

Requirement

The following Assessment Methods, or any combination of them, can be used to determine that a Building Solution complies with the Performance Requirements:

- (a) *Evidence to support that the use of a material, form of construction or design meets a Performance Requirement or a Deemed-to-Satisfy Provision as described in 1.2.2.*
- (b) *Verification Methods such as—*
 - (i) *the Verification Methods in the Building Code of Australia; or*
 - (ii) *such other Verification Methods as the appropriate authority accepts for determining compliance with the Performance Requirements.*
- (c) *Comparison with the Deemed-to-Satisfy Provisions.*
- (d) *Expert Judgment.*

Application

In this case, the opinion is based on compliance with paragraphs:

- (a) *Evidence to support that the use of a material, form of construction or design meets a Performance Requirement or a Deemed-to-Satisfy Provision as described in A2.2.*
- (b) *Verification Methods such as—*
 - (i) *the Verification Methods in the Building Code of Australia; or*
 - (ii) *such other Verification Methods as the appropriate authority accepts for determining compliance with the Performance Requirements.*
- (c) *Comparison with the Deemed-to-Satisfy Provisions.*

Clause 1.0.10 Relevant Performance Requirements

Requirement

The following method must be used to determine the Performance Requirement or Performance Requirements relevant to the Alternative Solution:

- (a) *Identify the relevant Deemed-to-Satisfy Provision of Section 3 that is to be the subject of the Alternative Solution.*
- (b) *Identify the Performance Requirements from Section 2 that are relevant to the identified Deemed-to-Satisfy Provisions.*
- (c) *Identify Performance Requirements from Section 2 that are relevant to any aspects of the Alternative Solution proposed or that are affected by the application of the Deemed-to-Satisfy Provisions, that are the subject of the Alternative Solution.*

Application

In this case, the opinion is based on full compliance with this paragraph.

Clause 1.2.1 Suitability of materials

Requirement

Every part of a building must be constructed in an appropriate manner to achieve the requirements of the Housing Provisions, using materials that are fit for purpose for which they are intended.

Application

In this case, the opinion is based on calculation that the Eco-Block Wall System satisfies this criterion.

Clause 1.2.2 Evidence of suitability

Requirement

- (a) *Subject to 1.2.3 and 1.2.4, evidence to support that the use of a material, form of construction or design meets a Performance Requirement or Deemed-to-Satisfy Provision may be in the form of one or a combination of the following:*
 - (i) *A report issued by a Registered Testing Authority, showing that the material or form of construction has been submitted to the tests listed in the report, and setting out the results of those tests and any other relevant information that demonstrates its suitability for use in the building.....*
 - (iii) *A certificate from a professional engineer or other appropriately qualified person which-*
 - (A) *certifies that a material, design or form of construction complies with the requirements of the Building Code of Australia; and*
 - (B) *sets out the basis on which it is given and the extent to which relevant specification, rules, codes of practice or other publication have been relied upon.*

- (iv) *A current certificate issued by a product certification body that has been accredited by the Joint Accreditation System of Australia and New Zealand (JAS-ANZ).....*
- (b) *Any copy of documentary evidence submitted, must be a complete copy of the original report or document.*

Application

In this case, the opinion is based on the following:

- Reference to reports issued by a registered testing authority as per paragraph (i). The reports shall be checked to ensure that they are complete, as per paragraph (b).

Specification 1.4.1

Table 1.4.1 Schedule of Referenced Documents

Application

The following referenced documents, called up in Building Code of Australia Vol 2 Table 1.4.1, provide the source documents used to: *Identify the relevant Deemed-to-Satisfy Provision, Identify the Performance Requirements and Identify Performance Requirements from other Sections and Parts that are affected by the application of the Deemed-to-Satisfy Provisions ...*

AS 3700-2001 Including Amendments 1, 2 and 3.

Particular Criteria Relating to Building Code of Australia Volume 2 (Class 1 & 10 Buildings)

Part P2.1 Structure

Performance Requirement

- (a) *A building or structure, to the degree necessary, must—*
- (i) *remain stable and not collapse; and*
 - (ii) *prevent progressive collapse; and*
 - (iii) *minimise local damage and loss of amenity through excessive deformation, vibration or degradation; and*
 - (iv) *avoid causing damage to other properties, by resisting the actions to which it may reasonably be subjected.*
- (c) *The structural resistance of materials and forms of construction must be determined using five percentile characteristic material properties with appropriate allowance for—*
- (i) *known construction activities; and*
 - (ii) *type of material; and*
 - (iii) *characteristics of the site; and*
 - (iv) *the degree of accuracy inherent in the methods used to assess the structural behaviour; and*
 - (v) *action effects arising from the differential settlement of foundations, and from restrained dimensional changes due to temperature moisture, shrinkage, creep and similar effects.*

State Variations

There are Queensland state variations related to termite management.

Compliance

Compliance with these performance requirements is set out in Section 3 and Appendix C of this manual, and consideration of AS 3700-2001.

Part 2.2.2 Weatherproofing and Part 2.2.3 DampnessPerformance Requirement*P2.2.2 Weatherproofing*

A roof and external wall (including openings around windows and doors) must prevent the penetration of water that could cause—

- (a) unhealthy or dangerous conditions, or loss of amenity for occupants; and
- (b) undue dampness or deterioration of building elements.

Limitation: P2.2.2(a) does not apply to Class 10 building except where its construction contributes to the weatherproofing of the Class 1 building

State Variations

Nil

Compliance

Compliance with these performance requirements is set out in Section 6 and Appendix G of this manual.

P2.4.6 Sound insulationPerformance Requirement

- (a) *Walls separating dwellings must provide insulation against the transmission of airborne sound sufficient to prevent illness or loss of amenity to the occupants.*

State Variations

In Northern Territory P2A.6 is replaced with the following:

P2.4.6 Sound insulation

- (a) *Walls separating dwellings must provide insulation against the transmission of airborne and impact generated sound sufficient to prevent illness or loss of amenity to the occupants.*

Compliance

Compliance with these performance requirements is set out in Section 5 and Appendix E of this manual,

3.12 Energy EfficiencyAcceptable construction practice

Deemed-to-Satisfy Provisions from BCA Vol 2 3.12.

State variations

In New South Wales BCA Volume 1 Section J is replaced by NSW Section J.

- For Class 2 and Class 4 buildings, NSW BASIX applies in accordance with NSW Subsection JA.
- For Class 3, 5, 6, 7a, 7b, 9a, 9b and 9c buildings, BCA Volume 1 Section J, in accordance with NSW Subsection JB.

In Northern Territory, BCA Volume 1 Section J does not apply.

Compliance

Compliance with these performance requirements is set out in Section 6 and Appendix F of this manual.

Appendix C

Structural Design

Introduction

This appendix should be read in conjunction with Section 3 Structural Design, for which it provided background and explanation. The design tables in that section are based on the method set out below.

The Detached, Duplex and Some Grouped Residential Eco-Block Wall Systems described in this manual are generally BCA Class 1(a) buildings that comply with the geometry limitations of AS 3700 Figure 12.1. They are an Australian adaptation of the Flat ICF Wall System, described in the following publication:

Prescriptive Design of Exterior Concrete Walls for One- and Two-Family Dwellings, Portland Cement Association National Standards Development Committee, PCA 100-2007

Three systems are covered by this manual:

- Eco-Block 230
- Eco-Block 280
- Eco-Block 330

The systems consist of:

- N20 (20 MPa) concrete core, either 101, 152 and 203 mm thick
 - Eco-Block 230 Series – Concrete core is 101 mm thick
 - Eco-Block 280 Series – Concrete core is 152 mm thick
 - Eco-Block 330 Series – Concrete core is 203 mm thick
- Two “flat” Class H expanded polystyrene ICF side panels, in accordance with AS 1366.3-1992, each measuring 1219 mm long x 406 mm high x 64 mm thick. Each pair of side panels is connected by a minimum of 12 Eco-Block propriety connectors at 203 mm centres horizontally.
 - Eco-Block 230 Series – Connector length is 101 mm
 - Eco-Block 280 Series – Connector length is 152 mm
 - Eco-Block 330 Series – Connector length is 203 mm
- Steel or equivalent fibres incorporated into the concrete, dosed at 24 kg/m³
- N12 L (700 x 260 cog) vertical starter bars, set in the concrete slab at centres set out in Table 3.1 to provide lap of 500 mm. As an alternative, it shall be permissible to set straight starter bars into the concrete slab with two part epoxy or equivalent.
- N12 vertical steel reinforcement at centres set out in Table 3.1, lapped 500 mm with the starter bars and cogged at the top of the wall to lap with the horizontal reinforcement
- At least one additional N12 vertical steel reinforcing bar adjacent to each opening
- 2-N12 bars or 1-N16 bar at the top of the wall, continuous around the building.
- Lintels as set out in Table 3.2, above each window and door opening and the 2-N12 bars continuous around the building.
- 1-N12 horizontal bar below each window opening

Commercial / Industrial Eco-Block Wall System

The Commercial / Industrial Eco-Block Wall Systems described in this manual are generally BCA Class 1(b), and Class 2 to 9 buildings that outside the geometry limitations of AS 3700 Figure 12.1. They are an Australian adaptation to the requirements of AS 3600 *Concrete structures*, of the Flat ICF Wall System, described in the following publication:

Prescriptive Design of Exterior Concrete Walls for One- and Two-Family Dwellings, Portland Cement Association National Standards Development Committee, PCA 100-2007

Three systems are covered by this manual:

- Eco-Block 230 CI
- Eco-Block 280 CI
- Eco-Block 330 CI

The systems consist of:

- N20 (20 MPa) concrete core, either 101, 152 or 203 mm thick
 - Eco-Block 230 CI Series – Concrete core is 101 mm thick
 - Eco-Block 280 CI Series – Concrete core is 152 mm thick
 - Eco-Block 330 CI Series – Concrete core is 203 mm thick
- Two “flat” Class H expanded polystyrene ICF side panels, in accordance with AS 1366.3-1992, each measuring 1219 mm long x 406 mm high x 64 mm thick. Each pair of side panels is connected by a minimum of 12 Eco-Block propriety connectors at 203 mm centres horizontally.
 - Eco-Block 230 CI Series – Connector length is 101 mm
 - Eco-Block 280 CI Series – Connector length is 152 mm
 - Eco-Block 330 CI Series – Connector length is 203 mm
- Reinforcement complying with AS 3600 for particular applications, including:
 - vertical loading;
 - out-of-plane horizontal loading; and/or
 - in-plane horizontal loading
 in accordance with the Building Code of Australia; and AS/NZS 1170.0, 1, 2 and 3 as applicable, and AS 1170.4.
- Details shall be generally as show in the following manual, but modified to suit the BCA and Australian Standards noted above.

Prescriptive Design of Exterior Concrete Walls for One- and Two-Family Dwellings, Portland Cement Association National Standards Development Committee, PCA 100-2007.

Worked Example

Detached, Duplex and Some Grouped Residential Eco-Block Wall System

The purpose of the following worked example is to provide guidance to structural engineers on the structural design considerations. The design process is based on AS 3700, with appropriate values reflecting the Eco-Block Wall System's properties.

Brief

Using the Detached, Duplex and Some Grouped Residential Eco-Block Wall System, determine the load capacities of the principal external walls (2.4 m high to top support x 6.6 m long between cross walls) building subject to lateral wind load and supporting a concrete slab. The wall does not have an opening.

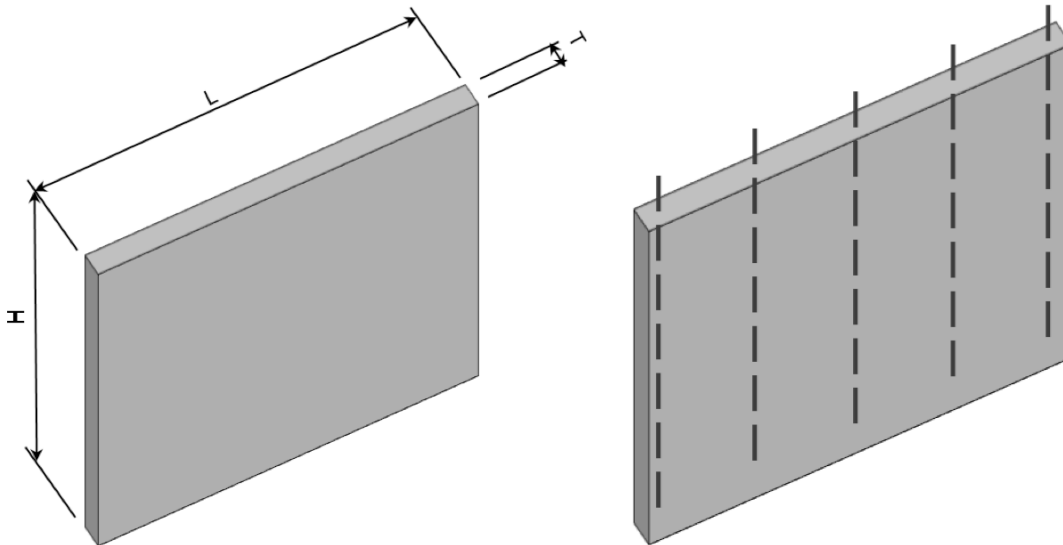

Wall Dimensions and Support

Height of wall
 $H = 2,400 \text{ mm}$

Length of wall
 $L = 6,600 \text{ mm}$

Thickness of concrete core of wall
 $T = 203 \text{ mm}$

Wall Support

The wall is supported top and bottom in simple vertical bending.

Concrete Properties

Concrete specification

Concrete grout shall comply with AS 3700 and have:

- a minimum portland cement content of 300 kg/cubic metre;
- a maximum aggregate size of 10 mm;
- sufficient slump to completely fill the cores; and
- a minimum compressive cylinder strength of 20 MPa.
- steel or equivalent fibres incorporated into the concrete, dosed at 24 kg/m³

Concrete strength
 $f'_c = 20 \text{ MPa}$

Specified value

Concrete shear strength
 $f'_{vm} = 0.35 \text{ MPa}$

AS 3700 Clause 3.3.4

Note

Using AS 3600 *Concrete structures*, significantly higher concrete shear strengths can be derived. However, the justification for this type of construction (wide-spaced reinforced wall panels) derives from comparison to AS 3700 *Masonry structures*, rather than to AS 3600. The value used in the calculations will be the conservative value given in AS 3700 Clause 3.3.4. Calculations indicate that this has no practical effect on capacity to resist horizontal pressures, since bending strength capacity governs in all practical design cases.

Reinforcement strength grade

$$f_{s y m} = 500 \text{ MPa}$$

Specified value

Main reinforcement shear strength (dowel action)

$$f_{s v} = 17.5$$

AS 3700 8.6.3

Note

As noted above, the methodology (and dowel strength) given in AS 3700 is used in preference to that in AS 3600, since the justification for this type of construction (wide-spaced reinforced wall panels) derives from comparison to AS 3700.

Reinforcement nominal diameter

$$R_{m \text{ dia}} = 12 \text{ mm}$$

Capacity Reduction Factors

Capacity reduction factor (similar to reinforced masonry)

$$\phi_r = 0.75$$

AS 3700 Table 4.1

Note

As noted above, the capacity reduction factor given in AS 3700 is used in preference to less conservative value given in AS 3600, since the justification for this type of construction (wide-spaced reinforced wall panels) derives from comparison to AS 3700.

Resistance to Bending (in the vertical direction)

Total length of wall

$$B_{\text{tot}} = 6,600 \text{ mm}$$

Number of reinforced members within the wall

$$N = 5$$

Spacing of reinforced members ((i.e. reinforcing bars) along the wall

$$B_{\text{space}} = 300, 1200, 1800, 1800, 1200, 300.$$

Design width of masonry supported by reinforced members

$$\begin{aligned} B &= \max (B_o, L/N) \\ &= \max (1,800, 6,600/5) \\ &= 1,800 \text{ mm} \end{aligned}$$

Width of concrete contributing to the flexural compression face of each reinforced member

$$\begin{aligned} b &= \min ([4 \cdot t_u + B_i], B) \\ &= \min ([(4 \times 203) + 0], 1,217) \\ &= 812 \text{ mm} \end{aligned}$$

Average shear width of each reinforced member

$$\begin{aligned} b_w &= \min ([4 \cdot t_u + B_i], B) \\ &= \min ([(4 \times 203) + 0], 1,217) \\ &= 812 \text{ mm} \end{aligned}$$

Note

The effective width for calculating shear resistance has been conservatively restricted to the same value as the flexural compression face of each reinforced member, i.e. 4.0 times the thickness of the reinforced concrete core.

Total depth of section

$$D_m = 203 \text{ mm}$$

Depth to the centroid of the tensile steel from the compression face

$$\begin{aligned} d &= D_m / 2 \\ &= 203 / 2 \\ &= 101 \text{ mm} \end{aligned}$$

Clear span of member

$$L_c = 2,400 \text{ mm}$$

Restraint at supports = Simply Supported

Shear coefficient

$$K_{\text{shear}} = 2$$

For "Simply Supported", use 2.00
For "Partially Restrained", use 1.60
For "Fully Restrained", use 2.00

Bending coefficient

$$K_{\text{bend}} = 9$$

For "Simply Supported", use 8
For "Partially Restrained", use 9
For "Fully Restrained", use 12

Area of all main tensile reinforcement bars in the member

$$A_{\text{st}} = 110 \text{ mm}^2 \text{ for a single N12 vertical bar}$$

Design area of main tensile reinforcement in the member

$$\begin{aligned} A_{\text{sd}} &= \min [0.29 (f'_c) b d / f_{\text{sy}}, A_{\text{st}}] \\ &= \min [(0.29 \times 20.0 \times 812 \times 101 / 500), 110] \\ &= \min [956, 110] \\ &= 110 \text{ mm}^2 \end{aligned}$$

Note

The term $1.3 f'_m$, used in AS 3700 is the estimate of equivalent cylinder strength of reinforced concrete masonry, i.e. the equivalent of f'_c for concrete.

Shear capacity

$$\begin{aligned} \phi_r V &= \phi_r (f'_{vm} b_w d + f_{vs} A_{\text{st}} + f_{sv} A_{\text{sv}} d / s) \\ &= 0.75 [(0.35 \times 812 \times 101) + (17.5 \times 110) + (500 \times 0 \times 100 / 0)] / 10^3 \\ &= 0.75 (10.7 + 1.9 + 0.0) \\ &= 23.1 \text{ kN/member} \end{aligned}$$

Bending moment capacity

$$\begin{aligned} \phi_r M &= \phi_r f_{\text{sy}} A_{\text{sd}} d [1 - 0.6 f_{\text{sy}} A_{\text{sd}} / (f'_c b d)] \\ &= 0.75 \times 500 \times 110 \times 76 [1 - (0.6 \times 500 \times 110) / (20 \times 812 \times 76)] / 10^6 \\ &= 4.10 \text{ kN.m/core} \end{aligned}$$

Load capacity (limited by shear)

$$\begin{aligned} \phi W_{\text{vr}} &= K_{\text{shear}} \phi_r V / (L_c k_u B) \cdot 10^3 \\ &= 2 \times 23.1 / (2,400 \times 1.0) \times 10^3 \\ &= 19.2 \text{ kN/ member} \end{aligned}$$

Load capacity (limited by bending moment)

$$\begin{aligned} \phi W_{\text{br}} &= K_{\text{bend}} \phi_r M / (L_c^2 k_{\text{mu}}) \cdot 10^6 \\ &= 9 \times 4.10 / (2,400^2 \times 1.0) \times 10^6 \\ &= 6.40 \text{ kN/ member} \end{aligned}$$

Load capacity (limited by shear or bending moment)

$$\begin{aligned} \phi W_r &= \min (W_{\text{vr}}, W_{\text{br}}) \\ &= \min (19.2, 6.40) \\ &= 6.40 \text{ kN/ member} \end{aligned}$$

Pressure capacity (limited by shear, bending moment)

$$\begin{aligned}\phi w_r &= \phi w_r / B \cdot 10^3 \\ &= 6.40 / 1,800 \times 10^3 \\ &= 3.66 \text{ kPa}\end{aligned}$$

Eco-Block Lintel Design Parameters

The following data is used in the determination of the tabulated permissible spans of Eco-Block lintels. The design methodology is as set out in the worked example that follows this data.

Capacity reduction factor	ϕ	0.75
Load factor on self weight contributing to failure	γ_C	1.20
Load factor on self weight resisting failure	γ_R	0.80
Concrete unconfined compressive strength	f'_{uc}	20 MPa
Density of concrete	γ_{conc}	2,500 kg/m ³
Concrete shear strength	f'_{vm}	0.35 MPa
Main reinforcement yield strength	f_{sy}	500 MPa
Main reinforcement shear strength (dowel action)	f_{vs}	17.5 MPa
Depth of W or V hanger of top steel (block to u/s of reo)	D_{hanger}	75 mm
Diameter of C lig reinforcement	$D_{dia C}$	10 mm
Fitment yield strength	$f_{sy f}$	500 MPa
Number of legs of fitment	N_f	1
Fitment area	A_f	78.5 mm ²
Fitment spacing	S	200 mm
Shear Factor for Lintels ($K_{shear} w L$)	K_{cont}	0.50
Bending Factor Continuous Lintels ($K_{cont} w L^2$)	K_{cont}	0.10
Bending Factor Simply Supported Lintels ($K_{simple} w L^2$)	K_{simple}	0.125
Deflection Factor Continuous Lintels ($K_{cont} w L^2$)	$K \Delta_{cont}$	0.00260
Deflection Factor Simply Supported Lintels ($K_{simple} w L^2$)	$K \Delta_{simple}$	0.1302
Deflection limit Span/....	Δ / L	360
Deflection limit	Δ	10 mm
Elastic modulus	E	20,000 MPa
Opening to hold down for uplift (each end)	l_1	0.100 m
Opening to centre of bearing for downwards (each end)	l_2	0.300 m
Typical truss spacing	S_t	0.900 m
Typical floor bearer spacing	S_t	0.900 m

Bending Moment and Shear Capacities of Various Configurations of Eco-Block Continuous Lintels											
Support Conditions & Load Direction	Width	Total depth	No of bars	Main reo	Fitment spacing	Inside dim of C fitment	Effective depth	Area of reo	Design area of reo	Design moment capacity	Design shear capacity
	B mm	D mm	N -	Reo -	S mm	C Mm	d mm	$A_{st\ act}$ mm ²	A_{st} mm ²	ϕ M kN.m	ϕ V kN
Continuous Lintels (Uplift)	101	200	1	N12	Nil	NA	86	110	100	2.7	3.7
	101	200	1	N16	Nil	NA	88	200	102	2.8	4.6
	101	300	1	N12	200	115	231	110	110	8.8	41.5
	101	300	1	N16	200	115	233	200	200	15.2	43.1
	101	400	1	N12	200	215	331	110	110	13.0	58.9
	101	400	1	N16	200	215	333	200	200	22.7	60.4
	101	500	1	N12	200	315	431	110	110	17.1	76.2
	101	500	1	N16	200	315	433	200	200	30.2	77.8
	101	600	1	N12	200	415	531	110	110	21.2	93.6
	101	600	1	N16	200	415	533	200	200	37.7	95.1
Continuous Lintels (Uplift)	152	200	1	N12	Nil	NA	86	110	110	3.1	4.9
	152	200	1	N16	Nil	NA	88	200	155	4.2	6.1
	152	300	1	N12	200	115	231	110	110	9.1	44.7
	152	300	1	N16	200	115	233	200	200	16.0	46.2
	152	400	1	N12	200	215	331	110	110	13.2	63.4
	152	400	1	N16	200	215	333	200	200	23.5	65.0
	152	500	1	N12	200	315	431	110	110	17.3	82.1
	152	500	1	N16	200	315	433	200	200	31.0	83.7
	152	600	1	N12	200	415	531	110	110	21.5	100.8
	152	600	1	N16	200	415	533	200	200	38.5	102.4
Continuous Lintels (Down)	101	200	1	N12	Nil	NA	114	110	110	4.0	4.4
	101	200	1	N16	Nil	NA	112	200	130	4.5	5.6
	101	300	1	N12	200	115	172	110	110	6.4	31.3
	101	300	1	N16	200	115	166	200	193	9.9	31.4
	101	400	1	N12	200	215	272	110	110	10.5	48.6
	101	400	1	N16	200	215	266	200	200	17.7	48.8
	101	500	1	N12	200	315	372	110	110	14.7	66.0
	101	500	1	N16	200	315	366	200	200	25.2	66.1
	101	600	1	N12	200	415	472	110	110	18.8	83.3
	101	600	1	N16	200	415	466	200	200	32.7	83.5
Continuous Lintels (Down)	152	200	1	N12	Nil	NA	114	110	110	4.3	6.0
	152	200	1	N16	Nil	NA	112	200	197	6.9	7.1
	152	300	1	N12	200	115	172	110	110	6.6	33.6
	152	300	1	N16	200	115	166	200	200	11.0	33.7
	152	400	1	N12	200	215	272	110	110	10.8	52.4
	152	400	1	N16	200	215	266	200	200	18.5	52.4
	152	500	1	N12	200	315	372	110	110	14.9	71.1
	152	500	1	N16	200	315	366	200	200	26.0	71.1
	152	600	1	N12	200	415	472	110	110	19.0	89.8
	152	600	1	N16	200	415	466	200	200	33.5	89.8

Bending Moment and Shear Capacities of Various Configurations of Eco-Block Simply Supported Lintels

Support Conditions & Load Direction	Width	Total depth	No of bars	Main reo	Fitment spacing	Inside dim of C fitment	Effective depth	Area of reo	Design area of reo	Design moment capacity	Design shear capacity
	B mm	D mm	N -	Reo -	S mm	C mm	d mm	$A_{st\ agt}$ mm ²	A_{st2} mm ²	ϕ M kN.m	ϕ V kN
Simply Supported (Uplift)	101	200	1	N12	Nil	NA	86	110	100	2.7	3.7
	101	200	1	N16	Nil	NA	88	200	102	2.8	4.6
	101	300	1	N12	200	115	231	110	110	8.8	41.5
	101	300	1	N16	200	115	233	200	200	15.2	43.1
	101	400	1	N12	200	215	331	110	110	13.0	58.9
	101	400	1	N16	200	215	333	200	200	22.7	60.4
	101	500	1	N12	200	315	431	110	110	17.1	76.2
	101	500	1	N16	200	315	433	200	200	30.2	77.8
	101	600	1	N12	200	415	531	110	110	21.2	93.6
	101	600	1	N16	200	415	533	200	200	37.7	95.1
Simply Supported (Uplift)	152	200	1	N12	Nil	NA	86	110	110	3.1	4.9
	152	200	1	N16	Nil	NA	88	200	155	4.2	6.1
	152	300	1	N12	200	115	231	110	110	9.1	44.7
	152	300	1	N16	200	115	233	200	200	16.0	46.2
	152	400	1	N12	200	215	331	110	110	13.2	63.4
	152	400	1	N16	200	215	333	200	200	23.5	65.0
	152	500	1	N12	200	315	431	110	110	17.3	82.1
	152	500	1	N16	200	315	433	200	200	31.0	83.7
	152	600	1	N12	200	415	531	110	110	21.5	100.8
	152	600	1	N16	200	415	533	200	200	38.5	102.4
Simply Supported (Down)	101	200	1	N12	Nil	NA	114	110	110	4.0	4.4
	101	200	1	N16	Nil	NA	112	200	169	5.5	5.6
	101	300	1	N12	200	115	172	110	110	6.4	31.3
	101	300	1	N16	200	115	166	200	200	10.2	31.4
	101	400	1	N12	200	215	272	110	110	10.5	48.6
	101	400	1	N16	200	215	266	200	200	17.7	48.8
	101	500	1	N12	200	315	372	110	110	14.7	66.0
	101	500	1	N16	200	315	366	200	200	25.2	66.1
	101	600	1	N12	200	415	472	110	110	18.8	83.3
	101	600	1	N16	200	415	466	200	200	32.7	83.5
Simply Supported (Down)	152	200	1	N12	Nil	NA	114	110	110	4.3	6.0
	152	200	1	N16	Nil	NA	112	200	200	6.9	7.1
	152	300	1	N12	200	115	172	110	110	6.6	33.6
	152	300	1	N16	200	115	166	200	200	11.0	33.7
	152	400	1	N12	200	215	272	110	110	10.8	52.4
	152	400	1	N16	200	215	266	200	200	18.5	52.4
	152	500	1	N12	200	315	372	110	110	14.9	71.1
	152	500	1	N16	200	315	366	200	200	26.0	71.1
	152	600	1	N12	200	415	472	110	110	19.0	89.8
	152	600	1	N16	200	415	466	200	200	33.5	89.8

Eco-Block Lintel – Worked Example

Brief

Calculate the permissible net upwards and downwards distributed loads that may be exerted on a 3.0 m continuous Eco-Block lintel as described below:

- Concrete: Width 152 mm, Depth 400 mm, Strength grade 20 MPa
- Main reinforcement 1-N16 bar in the top and 1-N16 bar in the bottom
- Ligatures N10 C @ 200 centres (External depth 235 mm)
- Hangers R4 V (Internal depth 75 mm)

Eco-Block Properties

Concrete characteristic unconfined compressive strength

$$f'_c = 20.0 \text{ MPa}$$

Concrete Grout Properties

Concrete grout specification

Concrete grout shall comply with AS 3700 and have:

- a minimum portland cement content of 300 kg/cubic metre;
- a maximum aggregate size of 10 mm;
- sufficient slump to completely fill the cores; and
- a minimum compressive cylinder strength of 20 MPa.
- Steel or equivalent fibres incorporated into the concrete, dosed at 24 kg/m³

Specified characteristic grout cylinder strength

$$f'_{cc} = 20 \text{ MPa} > 12 \text{ MPa} \quad \text{OK} \quad \text{AS 3700 Clause 5.6}$$

Design characteristic grout strength

$$\begin{aligned} f'_{cg} &= \min [(1.3 \times f'_c), 20.0] && \text{AS 3700 Clause 3.5} \\ &= \min [(1.3 \times 20.), 20.0] \\ &= \min [26.0, 20.0] \\ &= 20.0 \text{ MPa} \end{aligned}$$

Main Reinforcement Properties

Main reinforcement yield strength

$$f_{sy} = 500 \text{ MPa}$$

Main reinforcement shear strength (dowel action)

$$f_{sv} = 17.5 \text{ MPa}$$

Number of main tensile reinforcing bars

$$N_t = 1$$

Diameter of main tensile reinforcing bars

$$D_{dia t} = 16 \text{ mm}$$

$$\begin{aligned} A_{st} &= N_t (3.1416 D_{dia t}^2 / 4) \text{ (approx)} \\ &= 1 \times 3.1416 \times 16^2 / 4 \\ &= 200 \text{ mm}^2 \end{aligned}$$

Fitment Properties

Fitment yield strength

$$f_{sy f} = 500 \text{ MPa}$$

Number of legs of fitment

$$N_f = 1$$

Diameter of "C" ligature fitment reinforcement

$$D_{\text{dia C}} = 10 \text{ mm}$$

Fitment area

$$\begin{aligned} A_f &= N_f (3.1416 D_{\text{dia C}}^2 / 4) \\ &= 1 \times 3.1416 \times 10^2 / 4 \\ &= 78.5 \text{ mm}^2 \end{aligned}$$

Fitment spacing

$$s = 200 \text{ mm}$$

Dimensions

Width of lintel

$$B = 152 \text{ mm}$$

Depth of lintel

$$D = 400 \text{ mm}$$

Density of reinforced concrete core

$$\gamma_{\text{conc}} = 2,200 \text{ kg/m}^3$$

Depth of W or V hanger of top steel

(From top of block to underside of supported reinforcement)

$$d_1 = 75 \text{ mm}$$

Inside dimension of C ligature fitment

(From top of supporting reinforcement to underside of supported reinforcement)

$$\begin{aligned} d_2 &= 235 - 10 - 10 \\ &= 215 \text{ mm} \end{aligned}$$

Deflection Parameters

Limiting deflection

$$\Delta_a = \min (10, L/360)$$

Elastic modulus

$$\begin{aligned} E &= 1,000 f'_c \\ &= 1,000 \times 20.0 \\ &= 20,000 \text{ MPa} \end{aligned}$$

Deflection coefficients for continuous lintel

$$\begin{aligned} K_{\text{def}} &= 1 / 384 \\ &= 0.00260 \end{aligned}$$

Deflection coefficients for simply supported lintel

$$\begin{aligned} K_{\text{def}} &= 5/384 \\ &= 0.01302 \end{aligned}$$

Moment of inertia (based on gross section)

$$\begin{aligned} I &= B D^3 / 12 \\ &= 152 \times 400^3 / 12 \\ &= 0.8107 \times 10^9 \text{ mm}^4 \end{aligned}$$

Net Upwards Load

Effective depth for upwards load

$$\begin{aligned}d &= D - d_1 + D_{dia t} / 2 \\ &= 400 - 75 + 16/2 \\ &= 333 \text{ mm}\end{aligned}$$

Design area of main tensile reinforcement

$$\begin{aligned}A_{sd} &= \min [0.29 f'_c b d / f_{sy} , A_{st}] \\ &= \min [(0.29 \times 20.0 \times 152 \times 333 / 500) , 200] \\ &= \min [587 , 200] \\ &= 200 \text{ mm}^2\end{aligned}$$

Shear capacity

$$\begin{aligned}\phi V &= \phi (f'_{vm} b_w d + f_{vs} A_{st} + f_{sv} f A_{sv} d / s) \\ &= 0.75 [(0.35 \times 152 \times 333) + (17.5 \times 200) + (500 \times 78.5 \times 333 / 200)] / 1000 \\ &= 0.75 (17.7 + 3.5 + 65.4) \\ &= 65.0 \text{ kN}\end{aligned}$$

Bending Moment Capacity

$$\begin{aligned}\phi M &= \phi f_{sy} A_{sd} d [1 - 0.6 f_{sy} A_{sd} d / (1.3 f'_c b d)] \\ &= 0.75 \times 500 \times 200 \times 333 [1 - (0.6 \times 500 \times 200) / (20 \times 152 \times 333)] / 1,000,000 \\ &= 23.5 \text{ kN.m}\end{aligned}$$

Clear Span

$$L_c = 3.000 \text{ m}$$

Edge distance to the vertical anchorage reinforcement

$$L_{au} = 0.100 \text{ m}$$

Span for calculation of shear

$$\begin{aligned}L_{vu} &= L_c \\ &= 3.000 \text{ m}\end{aligned}$$

For shear due to uplift, the critical section of the beam is at the face of the support.

Span for calculation of bending moment

$$\begin{aligned}L_{mu} &= L_c + 2 L_{au} \\ &= 3.000 + (2 \times 0.100) \\ &= 3.200 \text{ m}\end{aligned}$$

For bending due to uplift, the beam will span between the closes vertical reinforcing bars that are fully anchored into the lintel/bond beam and the concrete slab below the wall.

Span for calculation of deflection

$$\begin{aligned}L_{\Delta u} &= L_c + 2 L_{au} \\ &= 3.000 + (2 \times 0.100) \\ &= 3.200 \text{ m}\end{aligned}$$

For deflection due to uplift, the beam will span between the closes vertical reinforcing bars that are fully anchored into the lintel/bond beam and the concrete slab below the wall.

Spacing of trusses exerting load on the lintel

$$S_u = 0.9 \text{ m}$$

Factor to account for increased shear due to point loads close to a support

$$\begin{aligned}k_{vu} &= (L_{vu} + S_u) / L_{vu} \\ &= (3.000 + 0.9) / 3.000 \\ &= 1.30\end{aligned}$$

This factor allows for the fact that a point load from a roof truss, supporting load over a distance of S_u , may be positioned immediately adjacent to the critical section, thus increasing the shear force on the over the value applicable to the uniformly distributed case.

Factor to account for increased moment due to point loads close to a support

$$\begin{aligned}k_{mu} &= (L_{mu} + S_u) / L_{mu} \\ &= (3.200 + 0.9) / 3.200 \\ &= 1.28\end{aligned}$$

This factor allows for the fact that a point load from a roof truss, supporting load over a distance of S_u , may be positioned at the centre of the span, thus increasing the bending moment over the value applicable to the uniformly distributed case.

Factor to account for increased deflection due to point loads close to a support

$$\begin{aligned}k_{\Delta u} &= (L_{\Delta u} + S_u) / L_{\Delta u} \\ &= (3.200 + 0.9) / 3.200 \\ &= 1.28\end{aligned}$$

This factor allows for the fact that a point load from a roof truss, supporting load over a distance of S_u , may be positioned at the centre of the span, thus increasing the deflection over the value applicable to the uniformly distributed case.

Limiting deflection

$$\begin{aligned}\Delta_a &= \min(10, L_c/360) \\ &= \min(10, 3,000/360) \\ &= 8.33 \text{ mm}\end{aligned}$$

Load capacity (limited by shear)

$$\begin{aligned}W_{vu} &= 2 \phi V / (L_{vu} k_{vu}) \\ &= 2 \times 65.0 / (3.000 \times 1.30) \\ &= 33.3 \text{ kN/m}\end{aligned}$$

Load capacity (limited by bending moment)

$$\begin{aligned}W_{mu} &= 10 \phi M / (L_{mu}^2 k_{mu}) \\ &= 10 \times 23.5 / (3.200^2 \times 1.28) \\ &= 17.9 \text{ kN/m}\end{aligned}$$

Load capacity (limited by deflection)

$$\begin{aligned}W_{\Delta u} &= \Delta_a E I / (K_{def} L_{\Delta u}^4 k_{\Delta u}) \\ &= 8.33 \times 20,000 \times 0.8107 \times 10^9 / (0.00260 \times 3,200^4 \times 1.28) \\ &= 386 \text{ kN/m}\end{aligned}$$

The allowable deflection has been based on the clear span, rather than the span between the vertical anchorage reinforcement.

Load capacity (limited by shear, bending moment or deflection)

$$\begin{aligned}W_{lu} &= \min(W_{vu}, W_{mu}, W_{\Delta u}) \\ &= \min(33.3, 17.9, 386.) \\ &= 17.9 \text{ kN/m}\end{aligned}$$

Factor on dead loads contributing to resistance

$$\gamma_R = 0.8$$

Factored self weight contributing to failure

$$\begin{aligned}W_{su} &= \gamma_R 0.0981 \gamma_{conc} B D \\ &= 0.8 \times 0.00981 \times 2,500 \times 152 \times 400 / 1,000,000 \\ &= 1.2 \text{ kN/m}\end{aligned}$$

Externally applied load capacity (adding self weight)

$$\begin{aligned}W_u &= W_{lu} + W_{su} \\ &= 17.9 + 1.2 \\ &= 19.1 \text{ kN/m}\end{aligned}$$

Net Downwards Load

Effective depth or downwards load

$$\begin{aligned}d &= d_1 + d_2 - 1.5 D_{dia} \\ &= 75 + 215 - (1.5 \times 16) \\ &= 266 \text{ mm}\end{aligned}$$

Design area of main tensile reinforcement

$$\begin{aligned}A_{sd} &= \min [0.29 (1.3 f'_m) b d / f_{sy} , A_{st}] \\ &= \min [(0.29 \times 1.3 \times 8.06 \times 190 \times 266 / 500) , 200] \\ &= \min [307 , 200] \\ &= 200 \text{ mm}^2\end{aligned}$$

Shear capacity

$$\begin{aligned}\phi V &= \phi (f'_{vm} b_w d + f_{vs} A_{st} + f_{sv} A_{sv} d / s) \\ &= 0.75 [(0.35 \times 152 \times 266) + (17.5 \times 200) + (500 \times 78.5 \times 266 / 200)] / 1000 \\ &= 0.75 (14.2 + 3.5 + 52.2) \\ &= 52.4 \text{ kN}\end{aligned}$$

Bending Moment Capacity

$$\begin{aligned}\phi M &= \phi f_{sy} A_{sd} d [1 - 0.6 f_{sy} A_{sd} d / (1.3 f'_m b d)] \\ &= 0.75 \times 500 \times 200 \times 266 [1 - (0.6 \times 500 \times 200) / (20.0 \times 152 \times 266)] / 1,000,000 \\ &= 18.5 \text{ kN.m}\end{aligned}$$

Clear Span

$$L_c = 3.000 \text{ m}$$

Edge distance to the centre of bearing

$$L_{ad} = 0.030 \text{ m}$$

Span for calculation of shear

$$\begin{aligned}L_{vd} &= L_c - 2 d \\ &= 3.000 - (2 \times 0.266) \\ &= 2.468 \text{ m}\end{aligned}$$

For shear due to uplift, the critical section of the beam is at a distance, d, from each face of the support.

Span for calculation of bending moment

$$\begin{aligned}L_{md} &= L_c + 2 L_{ad} \\ &= 3.000 + (2 \times 0.030) \\ &= 3.060 \text{ m}\end{aligned}$$

For bending due to downwards load, the beam will span between the positions in the supporting structure that has sufficient bearing strength to support the load.

Span for calculation of deflection

$$\begin{aligned}L_{\Delta d} &= L_c + 2 L_{ad} \\ &= 3.000 + (2 \times 0.030) \\ &= 3.060 \text{ m}\end{aligned}$$

For bending due to downwards load, the beam will span between the positions in the supporting structure that has sufficient bearing strength to support the load.

Spacing of floor bearers or other supports exerting load on the lintel

$$S_d = 0.9 \text{ m}$$

Factor to account for increased shear due to point loads close to a support

$$\begin{aligned}k_{vd} &= (L_{vd} + S_d) / L_{vd} \\ &= (2.468 + 0.9) / 2.468 \\ &= 1.36\end{aligned}$$

This factor allows for the fact that a point load from a floor bearer or other support, supporting load over a distance of S_d , may be positioned immediately adjacent to the critical section, thus increasing the shear force on the over the value applicable to the uniformly distributed case.

Factor to account for increased moment due to point loads close to a support

$$\begin{aligned} k_{md} &= (L_{md} + S_d) / L_{md} \\ &= (3.060 + 0.9) / 3.060 \\ &= 1.29 \end{aligned}$$

This factor allows for the fact that a point load from a floor bearer or other support, supporting load over a distance of S_d , may be positioned at the centre of the span, thus increasing the bending moment over the value applicable to the uniformly distributed case.

Factor to account for increased deflection due to point loads close to a support

$$\begin{aligned} k_{\Delta d} &= (L_{\Delta d} + S_d) / L_{\Delta d} \\ &= (3.060 + 0.9) / 3.060 \\ &= 1.29 \end{aligned}$$

This factor allows for the fact that a point load from a floor bearer or other support, supporting load over a distance of S_d , may be positioned at the centre of the span, thus increasing the deflection over the value applicable to the uniformly distributed case.

Limiting deflection

$$\begin{aligned} \Delta_a &= \min(10, L_c/360) \\ &= \min(10, 3,000/360) \\ &= 8.33 \text{ mm} \end{aligned}$$

Load capacity (limited by shear)

$$\begin{aligned} W_{vd} &= 2 \phi V / (L_{vd} k_{vd}) \\ &= 2 \times 52.4 / (2.468 \times 1.36) \\ &= 31.1 \text{ kN/m} \end{aligned}$$

Load capacity (limited by bending moment)

$$\begin{aligned} W_{md} &= 10 \phi M / (L_{md}^2 k_{md}) \\ &= 10 \times 18.5 / (3.060^2 \times 1.29) \\ &= 15.2 \text{ kN/m} \end{aligned}$$

Load capacity (limited by deflection)

$$\begin{aligned} W_{\Delta d} &= \Delta_a E I / (K_{def} L_{\Delta d}^4 k_{\Delta d}) \\ &= 8.33 \times 20,000 \times 0.8107 \times 10^9 / (0.0026 \times 3,060^4 \times 1.29) \\ &= 457 \text{ kN/m} \end{aligned}$$

The allowable deflection has been based on the clear span, rather than the span between the centres of bearing.

Load capacity (limited by shear, bending moment or deflection)

$$\begin{aligned} W_{ld} &= \min(W_{vd}, W_{md}, W_{\Delta d}) \\ &= \min(31.1, 15.2, 457.) \\ &= 15.2 \text{ kN/m} \end{aligned}$$

Factor on dead loads contributing to failure

$$\gamma_F = 1.2$$

Factored self weight contributing to failure

$$\begin{aligned} W_{sd} &= \gamma_F 0.0981 \gamma_{conc} B D \\ &= 1.2 \times 0.00981 \times 2,500 \times 152 \times 400 / 1,000,000 \\ &= 1.8 \text{ kN/m} \end{aligned}$$

Externally applied load capacity (subtracting self weight)

$$\begin{aligned} W_d &= W_{ld} - W_{sd} \\ &= 15.4 - 1.8 \\ &= 13.5 \text{ kN/m} \end{aligned}$$

Appendix D Fire Performance

Index to Test Reports

Set out below is an index to test reports, which form the basis of recommendations in this manual. To understand the way in which the recommendations have been derived, reference should be made to the complete test reports, since they contain the background, description of the tests and the results, necessary for correct interpretation. The complete test reports are available as separate files from the product supplier.

Test Opinion on Fire Resistance of Eco-Block wall systems to AS 1530.4 and AS 3600.

Result

System	Thickness of concrete core Mm	Fire Resistance Levels Structural / Integrity / Insulation mins / mins /mins
Eco-Block 230 CI	101	90/90/90
Eco-Block 280 CI	152	180/180/180
Eco-Block 330 CI	203	240/240/240
Walls must be supported top and bottom, and be designed in accordance with AS 3600.		

Laboratory BRANZ Limited, moonshine Road, Judgeford, New Zealand

Date 2/2/04

Reference FC2251

Construction Opinion on Fire Hazard Properties of Eco-Block wall systems, with internal plasterboard lining and external fibre-cement lining, as described below.

Opinion BRANZ opinion, "It is considered that Eco-Block wall systems with a plasterboard lining on the internal surface and a fibre-cement cladding on the external surface meets the performance requirements of the Building Code of Australia, 2005, CP4, and Part C1 Fire Resistance and Stability Clauses C1.10 Fire Hazard Properties (invoking specifications C1.10 and C1.10a) and Specification C1.1 Clause 2.4. Attachments not to impair fire-resistance on condition that:

- The internal plasterboard lining:
 - is not less than 10 mm thick;
 - is attached at no greater than 200 mm centres at the perimeter of a sheet and 400 mm centres horizontally and vertically in the field, with screws not less than 25 mm long to the plastic flanges
 - is taped and filled in accordance with the lining manufacturer's recommendations
 - complies with the Early Fire Hazard Indices or Group Number appropriate to the location and building class.
- The external fibre-reinforced cement lining is fixed at no greater than 200 mm centres at the perimeter of a sheet and 400 mm centres horizontally and vertically in the field, and finished in accordance with the lining manufacturer's recommendations.

Laboratory BRANZ Limited, moonshine Road, Judgeford, New Zealand

Date 20/1/06

Reference FSR 698

Test **UBC 26-3 Room Fire Test on Eco-Block wall with 12.5 plasterboard lining, but the forms were not concrete filled.**

Result After 15 minutes, the plasterboard had not become detached. The polystyrene had melted behind the plasterboard, but had not ignited.

Laboratory Omega point Laboratories
Date 22/1/99
Reference 15498

Test **Surface Burning ASTM E 84 97A**
Result Flame Spread Index 0 Smoke Index 300 (Terminated at 3 mins 32 secs)
Laboratory Celotex Corporation, 10301 Ninth Street, North St Petersburg, Florida
Date 28/4/98
Reference Job 258389I Metro-Dade CAE 98025

Test **Rate of burning of plastic connector material ASTM D635**
Result Average burning rate 1.43 cm/min
Laboratory Celotex Corporation, 10301 Ninth Street, North St Petersburg, Florida
Date 3/3/98
Reference Job 258389H Metro-Dade CAE 98024

Appendix E

Acoustic Performance

This manual reports the following tests and expert opinion by

Palmer Acoustics (Aust) Pty Ltd
 22 Burdekin Court, Hillcrest QLD 4118
 PO Box 165 Browns Plains QLD 4118
 Ph (07) 3802 8355
 Fax (07) 3802 8399
 ACN 058 751 349
 Email – paa@bigpond.net.au

Test
Result

Field Sound Transmission Loss Measurements (FSTC)

Based on the following field tests by Palmer Acoustics (Aust) Pty Ltd, ECO 280 (152 mm concrete core) has a predicted airborne sound transmission reduction in excess of $R_w + C_{tr}$ (airborne) of 50.

Airborne Sound Transmission Field Test Results			
System	FSTC	$D_{nt,w}$	C_{tr}
Test No 1 ECO 280 (152 mm concrete core) 19 Beale Street, Southport Qld	54	56	-4
Test No 2 ECO 280 (152 mm concrete core) 19 Beale Street, Southport Qld	54	56	-5

Laboratory Palmer Acoustics (Aust) Pty Ltd
Date 14/10/04
Reference 2107

Construction
Opinion

ECO 280 (152 mm concrete core)

Based upon our understanding of the system, experience with wall impact noise in many high rise residential buildings and as a practicing Acoustic Engineer (RPEQ, CPEng, NPER 3) I certify that the proposed system meets the BCA requirement to be sufficient to prevent illness or loss of amenity to the occupants, with regard to the isolation of impact noise. In this application the two 65mm thick polystyrene formwork panels serve to act as impact isolation elements serving to sufficiently decouple impact noise across the wall.

Laboratory Palmer Acoustics (Aust) Pty Ltd
Date 22/11/04
Reference Letter of Opinion, R Palmer

Appendix F

Thermal Performance

Method of Determining Thermal Resistance

The theoretical thermal resistance of the Eco-Block Wall System can be derived by:

- Using published data for the thermal conductivity and/or thermal resistance of the components, and assuming that they act in series.
 - Class H expanded polystyrene, in accordance with AS 1366.3-1992, minimum thermal conductivity, k , of 0.0400 W/m.K
 - Reinforced concrete thermal conductivity, k , of 1.44 W/m.K
 - Gypsum plasterboard thermal conductivity, k , of 0.170 W/m.K
 - Internal and external air film thermal resistances, $R = 0.03$ and $0.12 \text{ m}^2\text{.K/W}$, in accordance with the Building Code of Australia.
 - The thermal resistance of the external render, $R = 0.01$, in accordance with the following report in Appendix F. Willrath, H., *Thermal Properties of Eco-Block*, Solar Logic, 20/9/05.
- Assuming that all components act in series. This is based on the fact that the only components to cross the concrete core are the ties, and the bridging effect (parallel heat flow) would be minimal.

Further Reports of Thermal Resistance

The thermal resistances tabulated in this manual are minimum expected values, based principally on the minima specified in AS 1366.3-1992 for Class H expanded polystyrene. These are less than (and therefore more conservative than) the values reported in Willrath, H., *Thermal Properties of Eco-Block*, Solar Logic, 20/9/05, which is reproduced in the following pages.



Energy Efficiency and the BCA



The BCA contains energy provisions with the objective of reducing greenhouse gas emissions by efficiently using energy. The requirement is that a building must have, to the degree necessary, a level of thermal performance to facilitate the efficient use of energy for artificial heating and cooling.

BCA 2005

Currently this is to be achieved via

- **Thermal Simulation** A minimum performance standard equivalent to a NatHERS 3 1/2 star rating for the three cooling dominated climate zones (1, 2 & 3) and a 4 star rating for the remaining 5 climate zones (4 to 8). In climate zones 1, 2 & 3 there is an additional allowance of 20 MJ/m² for those dwellings that incorporate solar, gas or heat pump water heaters.
- Alternatively there is a raft of "Deemed to satisfy provisions" which can be adopted. These provisions relate to the building fabric, external glazing and shading, building sealing, and air movement.

The protocol for thermal calculation methods used to determine the energy rating of houses is detailed in the ABCB Protocol for House Energy Rating Software. Version 3.2 of BERS, version 3.5 of FirstRate and version 2.32 of NatHERS comply with this Protocol.

External walls

The deemed to satisfy alternative requires a minimum total R-value for walls to be as follows:

WALLS - MINIMUM TOTAL R-VALUE FOR EACH CLIMATE ZONE				
Climate zones	1, 2, 3 and 5	4 and 6	7	8
Minimum Total R-Value	1.4	1.7	1.9	2.8

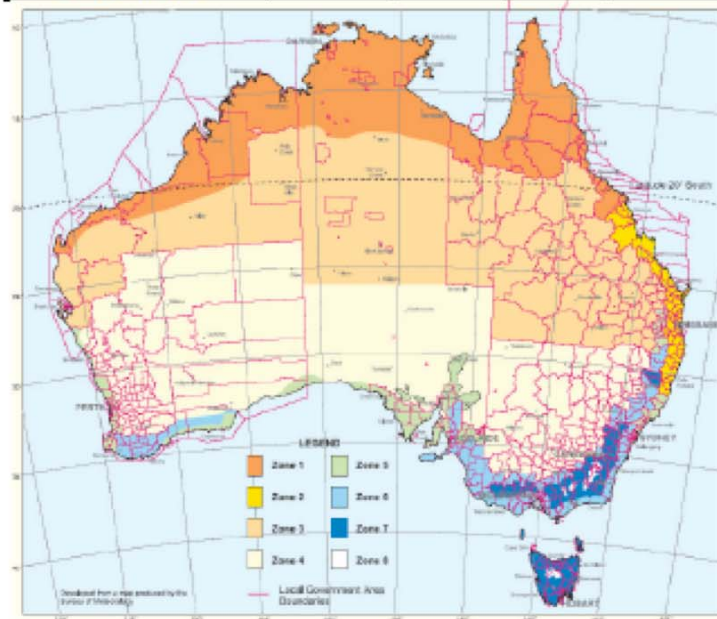

Dr Holger Willrath Solar Logic
 162 Blackwood St Mitchellton Q 4053
 Phone 07 3366 2808
 Web www.solarlogio.com.au
 email holger@solarlogio.com.au



Proposed Amendments BCA 2006 – Volume Two Page A2

The following amendments will take effect mid 2006

3.12.1.4 External walls

- (a) An external wall must satisfy one or a combination of the options in Table 3.12.1.3, except for-
 - (i) an external wall facing the south orientation sector, as described in Figure 3.12.2.1, in climate zones 1, 2 and 3 south of latitude 20° south; and
 - (ii) opaque non-glazed openings in external walls such as doors (including garage doors), vents, penetrations, shutters and the like.
- (b) Where the minimum Total R-Value specified in Table 3.12.1.3 cannot be achieved, the deficit may be compensated by the performance of the glazing, provided the sum of the conductance of the external walls and of the glazing is not more than that required, where-
 - (i) the conductance of the proposed design is calculated-
 - (A) for the external wall, by dividing its area by its Total R-Value; and
 - (B) for the glazing, by multiplying its area by its Total U-Value and the applicable frame factor in Table 3.12.2.2; and
 - (ii) the required conductance is calculated-
 - (A) for the external wall, by dividing its area by the applicable minimum Total R-Value specified in (a); and
 - (B) for the glazing, in accordance with 3.12.2.1(a)(i).
- (c) A metal framed wall that is required to achieve a minimum Total R-Value and has an external cladding of weatherboards, fibre cement sheet, or similar light weight material attached directly to the metal frame, must have a thermal break-
 - (i) installed between the metal frame and the external cladding; and
 - (ii) with an R-Value of not less than 0.2.
- (d) A wall is deemed to have the Total R-Value required by Table 3.12.1.3 if it complies with Figure 3.12.1.3.

Figure 3.12.1.3
TYPICAL INSULATION OPTIONS FOR TYPICAL WALL CONSTRUCTION

Climate zones	1, 2, 3 and 5	4 and 6	7	8
Minimum required Total R-Value for walls	1.9	2.2	2.4	3.3



Dr Holger Willrath Solar Logic
 162 Blackwood St Mitchellton Q 4053
 Phone 07 3366 2808
 Web www.solarlogio.com.au
 email holger@solarlogio.com.au



Thermal Properties of Eco-Block

The following R-Values have been calculated using the thermal properties of materials, air films and air spaces used in BERS or NatHERS.

EcoBlock

Element	thickness	R-Value
Outside Air Film		0.05
Outside Render	10	0.01
Expanded Polystyrene	65	1.82
Concrete	105	0.07
Expanded Polystyrene	65	1.82
Inside Render	10	0.01
Inside Air Film		0.11
Total R-Value		3.78
U-Value		0.26

U-Value, (conductance through the building element), is calculated by taking the reciprocal of the sum of the R-Values for the building element.

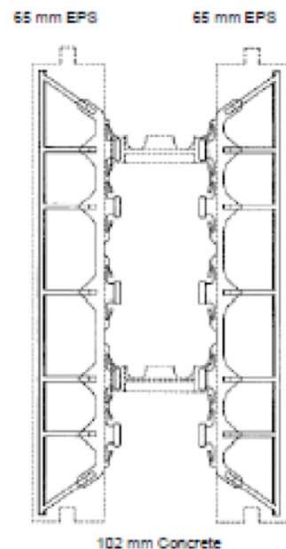

BCA Deemed to Satisfy Requirements

The total R-value achieved with the Eco-Block wall exceeds that required in all climate zones both under the current BCA and under the amendments proposed for mid 2008

Holger Willrath

20/09/2005



Dr Holger Willrath Solar Logic
 162 Blackwood St Mitchellton Q 4053
 Phone 07 3366 2808
 Web www.solarlogio.com.au
 email holger@solarlogio.com.au



Thermal Simulation of Eco-Block



Thermal Simulation with BERS3.2

Eco-Block can not be modelled directly with BERS3.2. The closest approximation is to select concrete block and the chose bulk insulation with an R-value of R3.6.

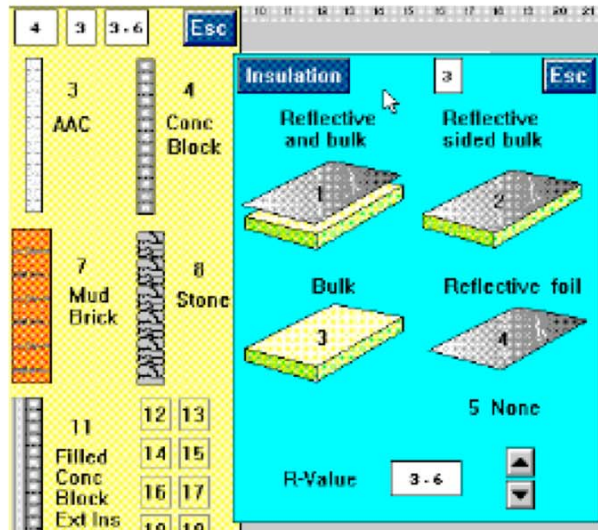

Thermal Simulation with BERS4.1

Eco-Block will have its own icon and thermal properties selectable from the BERS4.1 wall menu.

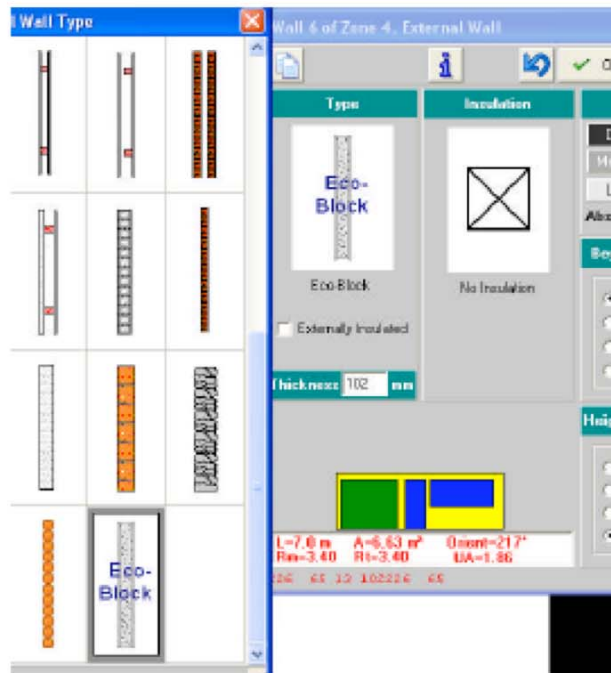

Holger Willrath
20/09/2005



Dr Holger Willrath Solar Logic
182 Blackwood St Mitoheilton Q 4063
Phone 07 3366 2808
Web www.solarlogio.com.au
email holger@solarlogio.com.au

Appendix G Detailing

Details shall be generally as show in the following manual, but modified to suit the BCA and Australian Standards noted above.

Prescriptive Design of Exterior Concrete Walls for One- and Two-Family Dwellings, Portland Cement Association National Standards Development Committee, PCA 100-

Appendix H Specifications

Scope

This sample specification covers the construction of Eco-Block Wall System in buildings, including reinforced lintels.

This sample specification are available in electronic format, with the express intention that designers will edit them to suit the particular requirements of specific construction projects. The design, construction and costing of structures must be carried out by qualified and experienced architects, engineers and builders. This sample specification has been prepared in the context of the Building Code of Australia. Architects, engineers and builders should make themselves aware of any recent changes to these documents, to any Standards referred to therein or to local variations or requirements. The authors, publishers and distributors of this specification and the associated details do not accept any responsibility for incorrect, inappropriate or incomplete use of this information.

To prepare a working specification for a particular contract, obtain an electronic version, and edit as appropriate.

Building Code of Australia and Standards

All materials and construction shall comply with the most recent version of:

- the relevant parts of the Building Code of Australia;
- the Standards referred to therein;
- other Standards nominated in this specification; and
- other relevant Regulations.

Relevant Standards and Documents

AS 3700 Masonry structures

AS/NZS 2699.2 Built-in components for masonry construction - Connectors and accessories

AS/NZS 2699.3 Built-in components for masonry construction - Lintels and shelf angles durability

AS 3660.1 Termite management – New Building work

AS 3660.2 Termite management – In and around existing buildings and structures - Guidelines

AS/NZS 4680 Hot-dip galvanised (zinc) coatings on fabricated ferrous articles

AS/NZS 4671 Steel reinforcing materials

AS 1397 Steel sheet and strip

AS 3600 Concrete structures

AS 2870 Residential slabs and footings – Construction

Commencement

Work shall commence as soon as practical after, but not before,

(a) The Builder has issued:

- a written order
- the relevant contract drawings, specifications and schedule of work
- written approval of any details provided by the Contractor

(b) Completion of supporting structures such as footings, concrete slab-on-ground or suspended concrete slabs.

Detached, Duplex and Some Grouped Residential Eco-Block Wall System

The Detached, Duplex and Some Grouped Residential Eco-Block Wall Systems described in this manual are an Australian adaptation of the Flat ICF Wall System, described in the following publication:

Prescriptive Design of Exterior Concrete Walls for One- and Two-Family Dwellings, Portland Cement Association National Standards Development Committee, PCA 100-2007

Two systems are covered by this manual:

- Eco-Block 230
- Eco-Block 280
- Eco-Block 330

The systems consist of:

- N20 (20 MPa) concrete core, either 101, 152 or 203 mm thick
 - Eco-Block 230 Series – Concrete core is 101 mm thick
 - Eco-Block 280 Series – Concrete core is 152 mm thick
 - Eco-Block 330 Series – Concrete core is 203 mm thick
- Two “flat” Class H expanded polystyrene ICF side panels, in accordance with AS 1366.3-1992, each measuring 1219 mm long x 406 mm high x 64 mm thick. Each pair of side panels is connected by a minimum of 12 Eco-Block propriety connectors at 203 mm centres horizontally.

Eco-Block 230 Series – Connector length is 101 mm
 Eco-Block 280 Series – Connector length is 152 mm
 Eco-Block 330 Series – Connector length is 203 mm

- Steel or equivalent fibres incorporated into the concrete, dosed at 24 kg/m³
- N12 L (700 x 260 cog) vertical starter bars, set in the concrete slab at centres set out in Table 3.1 to provide lap of 500 mm. As an alternative, it shall be permissible to set straight starter bars into the concrete slab with two part epoxy or equivalent.
- N12 vertical steel reinforcement at centres set out in Table 3.1, lapped 500 mm with the starter bars and cogged at the top of the wall to lap with the horizontal reinforcement
- At least one additional N12 vertical steel reinforcing bar adjacent to each opening
- 2-N12 bars or 1-N16 bar at the top of the wall, continuous around the building.
- Lintels as set out in Table 3.2, above each window and door opening and the 2-N12 bars continuous around the building.
- 1-N12 horizontal bar below each window opening

Commercial / Industrial Eco-Block Wall System

The Commercial / Industrial Eco-Block Wall Systems described in this manual is an Australian adaptation to the requirements of AS 3600 *Concrete structures*, of the Flat ICF Wall System, described in the following publication:

Prescriptive Design of Exterior Concrete Walls for One- and Two-Family Dwellings, Portland Cement Association National Standards Development Committee, PCA 100-2007

Two systems are covered by this manual:

- Eco-Block 230 CI
- Eco-Block 280 CI
- Eco-Block 330 CI

The systems consist of:

- N20 (20MPa) concrete core, either 101 mm or 152 mm thick
 - Eco-Block 230 CI Series – Concrete core is 101 mm thick
 - Eco-Block 280 CI Series – Concrete core is 152 mm thick
 - Eco-Block 330 CI Series – Concrete core is 203 mm thick
- Two “flat” Class H expanded polystyrene ICF side panels, in accordance with AS 1366.3-1992, each measuring 1219 mm long x 406 mm high x 64 mm thick. Each pair of side panels is connected by a minimum of 12 Eco-Block propriety connectors at 203 mm centres horizontally.

Eco-Block 230 CI Series – Connector length is 101 mm
 Eco-Block 280 CI Series – Connector length is 152 mm
 Eco-Block 330 CI Series – Connector length is 203 mm

Note:

In addition to these standard sizes, the core concrete thickness of Eco-Block walls may be used up to 600 mm.

- Reinforcement complying with AS 3600 for particular applications, including:
 - vertical loading;
 - out-of-plane horizontal loading; and/or
 - in-plane horizontal loading
 in accordance with the Building Code of Australia; and AS/NZS 1170.0, 1, 2 and 3 as applicable, and AS 1170.4.
- Details shall be generally as show in the following manual, but modified to suit the BCA and Australian Standards noted above.

Prescriptive Design of Exterior Concrete Walls for One- and Two-Family Dwellings, Portland Cement Association National Standards Development Committee, PCA 100-2007.

Flashings

Flashings shall be built into the wall in accordance with the Drawings, Building Code of Australia and relevant Standard (AS 3700). Unless stated otherwise, flashings shall be:

- Fixed with clouts to timber studs as applicable
- Turned up 150 mm and nailed to the frame or built 30 mm inside the wall,
- Positioned at openings (unless they are protected by an overhang), where they shall extend 100 mm past the end of opening and be turned up to prevent leakage.

Termite Protection

Termite protection measures shall comply with the Building Code of Australia and the relevant Standard (AS 3660.1)

The aim of most termite barriers is to force the termites to the surface of the structure, where they are visible and can be easily eradicated. Some termite barriers also include chemicals that deter the termites from passing. Other systems, involving chemical dosing and graded stone barriers may be applicable, but must be properly maintained. Refer to the relevant materials specifications.

Termite protection shall provide a continuous barrier that prevents termites from entering the building undetected. The critical areas for termite entry, including the external perimeter, construction joints and plumbing penetrations, shall be protected and treated by a termite management system. The system installation shall conform to the manufacturer's guidelines.

A manufacturer's warranty for a minimum of fifty (50) years shall be provided. The warranty shall be renewable on an annual basis, base on annual inspection by the system installation organisation. Such a warranty shall provide for timber replacement should a system breach occur.

A certificate permanently fixed to the building in a prominent location, such as a meter box, kitchen cupboard, or similar, shall indicate the following:

- Method of protection.
- Date of installation.
- Life expectancy of any termiticide and the required re-injection date.
- Installer's or manufacturer's recommendations for the scope and frequency of future inspections for termite activity, not greater than 12 months.

Sheet material acting as a termite barrier and their joints shall be constructed of termite-resistant materials, such that termites are unable to pass through them. The maximum aperture size of a perforated sheet material barrier shall be sufficiently small as to deny access to foraging termite species of the region. Combinations of materials likely to cause electrolytic reaction shall not be used, e.g. stainless steel mesh shall not be used in contact with mild steel reinforcement.

Flashings

Flashings shall comply with the Drawings, Building Code of Australia and relevant Standard (AS 3700, AS/NZS 2904).

- Metal and metal-cored flashings shall not be used in locations that expose them to saline ground water or rising salt damp.
- Metal flashings shall be compatible with the materials with which they are in contact, and shall not give rise to electrolytic action. If there is potential for electrolytic action to occur, flashings shall be isolated by inert materials.
- Flashings intended to hold their shape shall be manufactured from rigid material. (e.g. metal cored material)

Unless stated otherwise flashings shall consist of one of the following options:

Flashing in Concealed Locations (e.g. cavity flashings) shall be one of the following:

- Uncoated annealed lead having a mass not less than 10 kg/m^2 in lengths not exceeding 1.5 m, but shall not be used on any roof that is used to catch potable water;
- Uncoated copper having a mass not less than 2.8 kg/m^2 and having a thickness of 0.3 to 0.5 mm;
- Bitumen coated metal (normally aluminium) with a total coated thickness of 0.6 mm to 1.0 mm;
- Zinc coated steel with a thickness not less than 0.6 mm;
- Embossed/quilted polyethylene sheet with an average thickness not less than 0.5 mm

Flashings in Exposed Locations (e.g. flashings from the roof) shall be one of the following:

- Uncoated annealed lead having a mass not less than 20 kg/m^2 in lengths not exceeding 1.5 m, but shall not be used on any roof that is used to catch potable water;
- Uncoated copper having a mass not less than 2.8 kg/m^2 and having a thickness of 0.3 to 0.5 mm;
- Bitumen coated metal (normally aluminium) with a total coated thickness of 0.6 mm to 1.0 mm;
- Zinc coated steel of thickness not less than 0.6 mm.

Termite Barriers Consisting of Woven Stainless Steel Mesh

Woven stainless steel mesh acting as a termite barrier shall comply with the Drawings, Building Code of Australia and relevant Standard (AS 3660.1). Unless stated otherwise, properties shall be not less than the following:

- Mesh shall be woven wire from a fine wire loom.
- Wire shall be stainless steel grade 304 or 316 (AS 1449).
- Wire diameter shall be not less than 0.18 mm.
- Aperture size shall be not greater than 0.66 mm × 0.45 mm, except in those locations where a very small species of heterotermes vagus is present (e.g. parts of northern Australia), the aperture shall be reduced to a maximum of 0.40 × 0.40 mm
- Pipe collars, manufactured from woven stainless steel mesh with a 50 mm annulus, shall be attached to any penetrating service by a stainless steel clamp. Such collars shall be:
 - Embedded in the concrete; or
 - Clamped and parged to the top surface of the slab, and protected from damage by covering with a tile mortar bed or a false floors of cupboards or vanities. The clamp shall be sealed with the parging mix.

Termite Barrier Parging Material for Woven Stainless Steel Mesh

Parging material, for woven stainless steel mesh acting as a termite barrier, shall comply with the Drawings, Building Code of Australia and relevant Standard (AS 3660.1). Unless stated otherwise, parging material shall be a highly modified cementitious grout of a water-dispersed copolymer with a dry mixture of Type GP portland cement and sieved aggregate of a size that passes readily through the woven stainless steel mesh.

Hardened parging material shall provide:

- Termite resistance, when in contact with soil and termite workings;
- Bond strength (mesh to substrate) of not less than 1 kN/m at 28 days for a temperature range of 10°C to 30°C at a relative humidity range of 10%RH to 70%RH; and for at least 60 freeze-thaw cycles in saline solution between -15°C and 18°C.

Termite Barriers Consisting of Composite Fibre Blanket and Plastic Membrane with Termiticide Impregnation

Termite barriers, consisting of composite fibre blanket and plastic membrane with termiticide impregnation, shall comply with the Drawings, Building Code of Australia and relevant Standard (AS 3660.1). Unless stated otherwise, properties shall be not less than:

- Internal non-woven fibre blanket, not less than 200 grams per square metre,
- Impregnated with termiticide of pyrethroid deltamethrin crystals to a loading of not less than 1 gram per square metre (low toxicity to warm blooded animals which both strongly repels and kills termites),
- Bonded to a top moisture vapour barrier of low density polyethylene (LDPE), not less than 200 microns thick,
- Bonded to a bottom membrane of low density polyethylene (LDPE) not less than 50 microns thick, to prevent the termiticide leaching into soil.

Appendix I Sustainability

Part 1 – Sustainability Assessment Methodology

The sustainability of Eco-Block Wall System has been assessed in accordance with the ENVIROSPEC Protocol. The purpose of this Protocol is to define practical methodologies for classifying building products, such that their contribution to sustainability is easily identifiable. For purposes of this Protocol, sustainability is taken as those properties that lead to:

- Reduction in green-house gas generation, which causes global warming;
- Reduction in the use of non-renewable resources upon which our society depends; and
- Reduction in land, water or air pollution or degradation, which alienates the use of these resources.

It is recognised that the comparison of comprehensive life cycle analyses, prepared for competing products, is the most equitable basis of selecting sustainable products. However, comprehensive life cycle analyses are controversial, because they involve numerous assumptions regarding the manufacture, transport, construction, demolition and re-use of the building products; and assumptions regarding their in-service performance.

To date, Building Regulations have concentrated on only some aspects of in-service performance (e.g. specifying levels of insulation to achieve desired energy minimisation). The process of preparing such regulations has highlighted the problems in assessing the in-service performance of various products in various applications. (e.g. Differing thermal resistance and thermal mass of various building products will contribute differently to energy minimisation in different climates and different building types.)

Reflecting the current approach of building regulators, Part 2 of this Protocol considers the special circumstances of in-service performance criteria, in isolation from the other life-cycle considerations. It deals with the effects of a building product on the sustainable operation of the building into which it is built, in the context of what is both common practice and what is permissible under the Building Regulations. It provides for:

- Collection of data for subsequent use in life-cycle analysis; and
- Methods of classifying building products by their in-service effect in specific applications.

Once in-service data is gathered by the methods described in Part 2, it may be used as one of the inputs into a comprehensive life-cycle analysis used to produce Environmental Declarations. Such declarations should account for the sustainability impacts of the manufacture, transport, construction, demolition and re-use of building products, together with their in-service performance. They should comply with ISO/DIS 21930 as described in Part 1 of the Protocol. The following extracts from ISO/DIS 21930 provide context for Environmental Declarations in accordance with Part 1 of the Protocol.

If possible, Type III declarations for building products should account for all life cycle stages of the product. Omissions of life cycle stages shall be justified. Where not all the necessary information is available, the PCR shall state those stages that are to be addressed and how to deal with information gaps. The declarations may be based on generic data, as defined in the PCR.

Environmental impacts, e.g. energy and materials used, resulting from the installation of the building product in the building shall be identified and included in the report. If it is not included, because data is not available, this fact shall be stated.

Part 2 - Embodied Energy and Heating and Cooling Energy Associated with Eco-Block Wall System in Australian Buildings - Housing

Background

The BCA (Building Code of Australia) sets out the performance requirements for energy saving in Australian buildings⁴, and some DTS (deemed-to-satisfy) forms of construction. Both the performance requirements and the DTS provisions are based on minimising heating and cooling energy, and do not give requirements for minimising the embodied energy used to manufacture the building components.

Scope

This Appendix provides estimates of the embodied energy used to manufacture Eco-Block Wall System wall systems, and compares it to a selected benchmark (clay masonry veneer), commonly used in Australian housing. From this data, the savings in embodied energy to change from the benchmark system to Eco-Block Wall System can be calculated, and this information can be expressed as a percentage of the heating and cooling energy over the life of the house.

Form of Construction

Eco-Block Wall System is often constructed as single-leaf with roof overhangs.

Limitations

This is a preliminary study based on a limited amount of information, and should be augmented by a more comprehensive study. It does not consider credits for reuse of materials during the final demolition. Nor does it include painting and maintenance of non-face-brick components.

Analysis

- Table 1 shows the embodied energy of various external wall systems, including clay masonry veneer, Eco-Block Wall System single leaf and Eco-Block Wall System veneer. Embodied energy values are expressed as MJ/m² of wall area.
- Table 2 shows the embodied energy saving to change construction from clay brick veneer to Eco-Block Wall System single leaf or Eco-Block Wall System veneer.

Conclusions

- Table 1 shows that the embodied energies of Eco-Block Wall System Single Leaf wall system consumes ##### embodied energy than the selected benchmark construction (clay masonry veneer).
- Table 2 shows that the small changes (positive or negative) in embodied energy, resulting from changing construction from the clay brick veneer benchmark to Eco-Block Wall System, are ##### when compared with the target operational 5 Star heating and cooling energy expended over the life of the building.

⁴ In this Appendix, the comparisons are made for housing complying with BCA Volume 2.

Table 1 - Embodied Energy of Various Wall Systems

Climate Zone	Embodied Energy MJ/m ² wall		
	Clay Masonry Veneer	Eco-Block Wall System Single Leaf	Eco-Block Wall System Veneer
1 Hot humid warm winter	590	#	#
2 Warm humid summer, mild winter	590	#	#
3 Hot dry summer warm winter	590	#	#
4 Hot dry, cool winter	590	#	#
5 Warm temperate	590	#	#
6 Mild temperate	590	#	#
7 Cool temperate	590	#	#
8 Alpine area	610	#	#

Notes:

- The insulation of all systems is in accordance with the BCA-2006 Volume 2 requirements and the corresponding Deemed-to-Satisfy details.
- Tabulated values are the sum of the embodied energies of the principal components making up the wall.

Table 2 - Embodied Energy Saving to Change Construction From Clay Brick Veneer To Eco-Block Wall System Single Leaf or Eco-Block Wall System Veneer

Climate Zone	5 Star Heating & Cooling Energy (MJ/m ² wall over life)	Embodied Energy Reduction, if construction is changed from Clay Masonry Veneer to Eco-Block Wall System	
		MJ/m ² wall	% of Heating & Cooling Energy over life of building)
		Eco-Block Wall System #	Eco-Block Wall System #
1 Hot humid warm winter	24,624	#	#
2 Warm humid summer mild winter	6,926	#	#
3 Hot dry summer, warm winter	10,004	#	#
4 Hot dry, cool winter	12,697	#	#
5 Warm temperate	8,465	#	#
6 Mild temperate	14,236	#	#
7 Cool temperate	19,238	#	#
8 Alpine area	16,545	#	#

Notes:

The insulation of all systems is in accordance with the Draft BCA-2006 Volume 2 requirements and the corresponding Deemed-to-Satisfy details.

Positive values in this table indicate that the particular system (Eco-Block Wall System Single Leaf) has consumed more embodied energy than the corresponding clay masonry veneer system.

Negative values in this table indicate that the particular system (Eco-Block Wall System Veneer) has consumed less embodied energy than the corresponding clay masonry veneer system.

Methodology

The methodology employed herein is as follows. For a range of common Australian house building components in each Climate Zone:

1. From published data, determine the embodied energy per unit mass of common building components.
2. Determine the mass and embodied energy of each selected component and its most common alternatives
 - Eco-Block Wall System single leaf wall
 - Eco-Block Wall System veneer wall
 - Clay brick veneer wall (benchmark construction)
3. Determine the embodied energy difference, to change to the principal component from the benchmark form of construction.
4. Using the ABCB Protocol energy software, determine the target heating and cooling energy consumption for each relevant location.⁵
5. Compare the embodied energy difference (to change from the principal component to the alternative form of construction) to target 5 star heating and cooling energy consumption.^{6 7}

Criterion: “ have lower embodied energy than commonly available alternatives.”

Benchmark

For external walls, the “commonly used alternatives” referred to in this statement are:

Clay masonry veneer walls, consisting of 230 x 76 x 110 mm extruded clay bricks, set in 1:1:6 mortar, supported by 70 mm MGP10 timber stud wall, with 10 mm plasterboard lining and incorporating bulk insulation nominated in BCA Volume 2 Part 3.12.

Climate Zone	Embodied Energy (MJ/m ² wall) for Clay Masonry Veneer
1 Hot humid warm winter	590
2 Warm humid summer, mild winter	590
3 Hot dry summer, warm winter	590
4 Hot dry, cool winter	590
5 Warm temperate	590
6 Mild temperate	590
7 Cool temperate	590
8 Alpine area	610

⁵ A more sophisticated approach is to analyse each house design using conforming software (e.g. AccuRATE). However the approach used in this paper is considered to be more appropriate for comparing embodied energies, since most houses will suffer various limitations of site orientation, shading etc. and will probably only “just” achieve the required energy consumption defined in the ABCB Protocol.

⁶ The “savings” are expressed as a percentage of the Heating and Cooling energy, calculated using the ABCB Protocol for House Energy Rating Software Version 2006.1.

⁷ The calculated values for embodied energy are considered to be very low proportions of heating and cooling energy. Total life-cycle energy of a house is much higher (7 to 8 times higher) than the heating and cooling energy. If embodied energy saving were treated as a proportion of total life-cycle energy rather than of heating and cooling energy, the proportions would go from very small to insignificant. This suggests that there are far more significant savings in energy and greenhouse gas emissions to be made through controlling house operational energy (appliances etc) than by attempting to control embodied energy of the building fabric.

Compliance:

Compliance with this criterion shall be substantiated by evidence that the product has Embodied Energy less than the benchmark clay masonry veneer walls.

Eco-Block Wall System Manufacturing Process

The manufacturing process consists of the following:

- #####.

Embodied energy per unit mass of common building components

The embodied energy of particular building materials depends in part on the country of origin and the process involved in manufacture. There are many sources of information on embodied energy of materials, some of which are available on the Internet. The following have been chosen for use in this report.

Estimated Embodied Energy of Common Building Components			
Material	Approximate Density, kg/m ³	Embodied Energy ¹ MJ/kg	Embodied Energy MJ/ m ³
Eco-Block Wall System blocks	###	### ^{Note 3}	###
Brick (clay)	1,700	2.5 ^{Note 1, 2}	4,250
Concrete	2,360	1.9	4,480
Plasterboard	880	6.1	5,368
Kiln dried, dressed timber	510	2.5	1,280
Fibreglass Insulation	18	30.3	550
Polystyrene Insulation	16	117	1,870
Sand & aggregate	1,700	0.8	1,360
Cement	1,500	5.6	

Notes

1. For consistency of comparisons, the values of embodied energy per unit mass of common building components have all been drawn from a common source. This is considered to be the most appropriate approach, notwithstanding that the use of energy in the manufacture of products varies from plant to plant.

Typical Relationship between Net Area of External Wall and Floor Area of Habitable Rooms

The values tabulated below are the prescribed limits on energy consumption for the total of heating and cooling per unit floor area of habitable room. This area is different from the net area of external wall (which incorporates the wall embodied energy).

The relationship between net area of external wall and floor area of habitable rooms depends on the building dimensions, window and door areas, proportion of habitable to non-habitable rooms and height of sub-floor. The relationship could also vary a little depending on whether the house is one or two storey, although this effect is minor provided suitable adjustment to the other inputs is made.

The following calculations determine a typical relationship between net area of external wall and floor area of habitable rooms, and will be used in subsequent calculations.

Typical Relationship Between Net Area of External Wall and Floor Area of Habitable Rooms		
Length	15.0	m
Width	10.0	m
Floor to ceiling height	2.4	m
Subfloor height	0.3	m
Total wall height	2.7	m
Proportion habitable floor	15%	
Windows & door area (Including jambs, sill etc)	36	m ²
Internal gross wall area (including windows & doors)	120	m ²
(Windows + doors) / Wall	30%	
Net external wall area (based on total wall height)	99	m ²
Habitable floor area	128	m ²
Net external wall area / Habitable floor area	77%	

Target 5 Star Heating and Cooling Energy Consumption

Target Heating and Cooling Energy to Achieve 5 Star Performance MJ/m ² based on <u>Habitable Floor Area</u>				
Zone	Representative City		5 Star Annual Energy Limit MJ/m ²	5 Star Lifetime Energy Limit MJ/m ²
1 Hot humid warm winter	Darwin	1	320	19,200
2 Warm humid summer, mild winter	Brisbane	10	90	5,400
3 Hot dry summer, warm winter	Alice Springs	6	130	7,800
4 Hot dry, cool winter	Tamworth	14	165	9,900
5 Warm temperate	Sydney (East)	17	110	6,600
6 Mild temperate	Melbourne	21	185	11,100
7 Cool temperate	Hobart	25	250	15,000
8 Alpine area	Alpine	26	215	12,900

Notes

1. Annual energy limit from ABCB Protocol Building Energy Analysis Software Version 2005.1 May 2005.
2. The energy consumption values are total of heating and cooling per unit floor area of habitable rooms.
3. Lifetime energy limit is based on 60 years building life.

Target Heating and Cooling Energy to Achieve 3 or 5 Star Performance MJ/m ² based on <u>Net External Wall Area</u>				
Zone	Representative City		5 Star Annual Energy Limit MJ/m ²	5 Star Lifetime Energy Limit MJ/m ²
1 Hot humid warm winter	Darwin	1	410	24,624
2 Warm humid summer, mild winter	Brisbane	10	115	6,926
3 Hot dry summer, warm winter	Alice Springs	6	167	10,004
4 Hot dry, cool winter	Tamworth	14	212	12,697
5 Warm temperate	Sydney (East)	17	141	8,465
6 Mild temperate	Melbourne	21	237	14,236
7 Cool temperate	Hobart	25	321	19,238
8 Alpine area	Alpine	26	276	16,545

Notes

1. Annual energy limit from ABCB Protocol for Building Energy Analysis Software Version 2005.1 May 2005.
2. The energy consumption values are total of heating and cooling per unit net external wall area of habitable rooms.
3. Lifetime energy limit is based on 60 years building life.



ABN 31 088 338 532 Inc in NSW
www.electronicblueprint.com.au
info@electronicblueprint.com.au

Quasar Management Services Pty Ltd

ABN 21 003 954 210 Inc in NSW

This manual has been prepared for Eco-Block Australia by Electronic Blueprint, based on engineering input by Quasar Management Services Pty Ltd. For further technical assistance, please contact www.electronicblueprint.com.au.

ELECTRONIC BLUEPRINT is the principal point of reference for Architects, Engineers and Builders and the only package that fully integrates regulatory and standards requirements with comprehensive, editable specifications, CAD details and approved industry training.



Copyright & Licence

© Quasar Management Services Pty Ltd. All rights are reserved. A licence for the unlimited use of this material is granted to Eco-Block Australia. Permission is also granted to Architects, Engineers and Builders to use this material in the preparation of specific designs, specification and contracts.